



OCT 92

GLEANINGS IN

BEE CULTURE



WAX WORKS

All That Equipment

FALL FEEDING

Take O.B. Wiser's Advice

MOLDED CANDLES

How-To For Home Or Gifts

ADEE HONEY FARMS

Making The Mississippi Split



JOHN ROOT

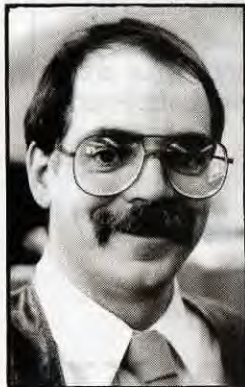
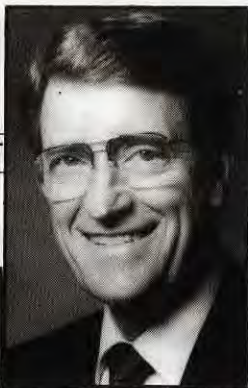

KIM FLOTTUM

THE A. I. ROOT CO., Publishers
623 W. LIBERTY STREET
MEDINA, OHIO 44256

Copyright © 1992 by The A. I. Root Co.
All rights reserved.

John Root Publisher
Robert Stanners Assoc. Publisher
Kim Flottum Editor

Kathy Summers Production Coordinator
Moonlight Graphics Photo Production
Buzz Phillips Circulation Director

Contributors

- Roger Morse • Richard Taylor •
- Michael Burgett • Dewey Caron •
- Richard Bonney • Sue Cobey •
- Clarence Collison • Tom Sanford •
- B. A. Stringer •

SUBSCRIPTION RATES: United States, one year, \$14.40; two years, \$27.00. Newsstand Price: \$1.95. All other countries (U.S. Currency only), \$7.50 per year additional for postage. Published monthly. Change of Address: Return completed form inside issue. Articles are solicited. Opinions expressed by the authors are not necessarily those of the publishers.

Advertising: For Display advertising information contact Dawn Feagan at our office at 216-725-6677 Ext. 220.

POSTMASTER: Please send form 3579 to: The A. I. Root Co., 623 W. Liberty St., Medina, OH 44256. Tele. 216-725-6677.

Circulation Figures reviewed by Deloitte & Touche. CPAs.

Columns

- **Do You Know?** Clarence Collison 545
Producing A Quality Product.
- **Nectar On My Boots** Tom Sanford 556
Making Candy Boards.
- **Home Harmony** Ann Harman 568
Halloween Goodies!
- **Bee Talk** Richard Taylor 575
Possible Solutions To Real Problems.

Departments

- The Inner Cover Kim Flottum 536
Treating Tracheal Mites; Bees on TV
- Mailbox Reader's Forum 539
Condos confirmed; Used jars; Politics; IPM pays
- October Honey Price Report Field Reporters 542
- Questions & Answers Richard Taylor 577
Requeening; Fall feeding; Excluders
- The Globe News & Events 579
ABF meeting; Bees on TV; Canada's count
- Classified Advertising Bargain Pages 584
- Bottom Board Gwen Eisenman 588
Where did the bees come from, and why do birds peck at windows?

COVER ... Bee Bee Trees were once hailed as the perfect honey plant. While that claim isn't as loud as it once was, this tree can play an important role in a honey season. Find out all about Bee Bee Trees, on page 564.

photo by Kim Flottum

OCT '92 CONTENTS

(ISSN 0017-114X)

Vol. 120, No. 10

119 Years Continuous Publication by the Same Organization

is removed but
A bottom, cleat
is added and it is
next yard the
the bottom box
has a new top

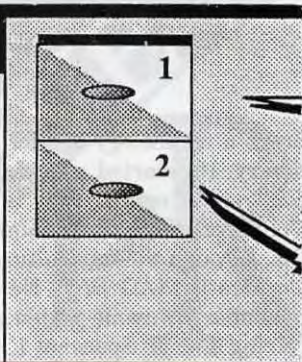

Mississippi Split, Pg. 560

Features



Fall Feeding, Pg. 558



Molded Candles, Pg. 570

- **WAX WORKS**Jeff Ott **546**
Handling cappings wax is part of beekeeping. If you're going to upgrade, or are just thinking of improving that part of your operation - here's everything you need to know about available equipment.
- **CAPPINGS**Roger Morse **552**
Low tech is how most of us handle cappings, and, as is often said, "there is no easy way, but there are lots of ways"
- **FALL FEEDING**O.B. Wiser **558**
You shouldn't have to if things go right, but if they don't here's how.
- **MISSISSIPPI SPLIT**Kim Flottum **560**
Adee Honey Farms starts moving bees this month from up north to Mississippi. There, next spring they turn 10,000 doubles into more than 45,000 honey producing colonies. This is how they do it.
- **BEE BEE TREE**B.A. Stringer **564**
Our cover photo this month shows just how attractive this plant is - our story tells why.
- **MEET JOHN MILLER**Kim Flottum **566**
This newest Honey Board Director comes with lots of experience, and lots of history.
- **MAKING MOLDED CANDLES**Dick Bonney **570**
Beeswax is a valuable product, but candles made from beeswax are even more valuable. Here's how to make beautiful molded candles this year.
- **BRANDIES & CORDIALS**
FROM HONEY, OF COURSEPamela Spence-Allen **574**
Easy and fast, these honey enhanced drinks are just in time for holiday festivities.

INNER COVER

You absolutely must consider control of tracheal mites in your bees. Knowing how to examine bees for mites is a valuable skill, and one you should have. But if you gamble at all you can bet at least some of your bees have mites, and maybe all have mites. They are endemic, universal and deadly.

So, check if you must (and can), but treat without exception. What to use? There's only two choices, and you probably know them both – menthol crystals and grease patties.

Menthol works. Or, at least menthol works when the weather's right. Too cool (outside temperature below 60°F), and the crystals won't evaporate, the bees won't breathe the vapor and the mites won't die.

Too warm (outside temperature above 100°F) and the crystals melt and the mess is well, a mess. And the mites still don't die.

Between those two extremes menthol should work pretty well. But if the weather's cool, and tends more toward 60° than 90°, treatments will be uneven and unpredictable. A common complaint because the weather, at least north of the Mason/Dixon line often tends more toward 60° than not.

And menthol's not free, either. If you suspect menthol will work – use it. You'll have bees next spring. But if the Arctic Circle is less than a day's drive you should consider not trying it – because it probably won't work. In fact, it'll probably be there next spring. Right where you put it this fall. You'll find it right next to the dead bees and all the honey they left. Nope, it probably won't work.

But as soon as I say that, we'll have the warmest fall on record and 80° days will be common til Christmas. So be careful. Be extra careful. And beware the advice of "experts"

But if not menthol – what? Well, grease patties have been shown to work. Simply mix two parts sugar with one part solid vegetable shortening, measure out a half cup or so and squash it between two sheets of wax paper. Plop this on the top bars and let the bees chomp on it all winter (or as much as mother nature will let them).

Since mites tend to concentrate in older bees, winter-cluster-time is the perfect exposure period to what ever it is in grease patties that makes mites go away. It's not foolproof, though, so don't think you can fool mother nature. But it is effective, it is cheap, and it is legal. A 1, 2, 3, combination in my opinion.

But are you really concerned? Worried that all the above still won't work? Try both! Put both menthol *and* patties on your colonies. Research shows this double treatment is *more* than double effective. Try it this fall – let us know.

There's even another trick we've heard this year. And, it just goes to show you.

Back during the early days of patty research, some beekeepers were reporting adequate mite control when using the grease patties as a carrier for Terramycin™ in controlling American foulbrood. At the time it was thought it was the vegetable oil that was at work and since then it has been shown it was *part* of the solution. Or so it seems.

Recent work has come out suggesting it was the *combination* of vegetable oil and Terramycin™ that was working so well. Several studies are underway now to see if that's the case. Maybe it is. So, if you're in a trial and error mood, consider all of the above.

But for goodness sake do SOMETHING for tracheal mites now, or you will certainly need to read the article we've slated for early spring – "Dealing With The Dead"

broke a technology barrier for this industry. He started a for-college-credit beekeeping course that is taught in Columbus, Ohio, and beamed by satellite, through the Agricultural Satellite Corporation (AG*SAT) Network. It is available to anyone with a satellite receiving dish on Spacenet 1, Channel 5.

The course runs from 5:30 p.m. until 7:30 p.m. (EST) on Wednesdays until Dec. 9. There's 15 classes in all.

The topics covered include: History & Development • Equipment • Colony Manipulation • Getting into a beekeeping business and the U.S. beekeeping industry • Honey bee biology and swarming • Pollination • Honey, Nectar and Pollen sources • Colony products • Honey bee anatomy • The sting, and stinging insects • The Queen • Maladies of honey bees • The Africanized honey bee • Honey bees in Summer • Honey bees in Winter • Good Neighbor beekeeping.

If you take the class for credit it is two semester hours or three quarter hours. And, there is a written final. However, if you're in it for fun, just watch and enjoy.

The show has live segments and some prerecorded video sections that help demonstrate each topic. There's also a live, toll-free call-in portion at the end of the show so if there's something you didn't understand you can call and ask. Obviously not all calls will get answered on air, but if you call, Dr. Tew will answer it the next week.

Along with all this there will be guests 'dropping in' that in some way reflect the nature of the particular show. That's where I come in.

I was the guest on the very first show that aired on September 2, 1992.

Continued on Page 586

Treat

On a much more cheerful note, in early September Dr. James E. Tew

SAVE PRICE NOW INCREASE

Yes, the cost of doing business has finally caught up with us. We've sharpened our pencils, cut all the right corners, taken advantage of all the specials and everything we could think of to keep costs down, and it's worked for almost two years. But we can't hold back anymore.

BUT YOU CAN BEAT THE PRICE INCREASE IF YOU ACT NOW BECAUSE IN JANUARY THE COST OF A SUBSCRIPTION GOES UP.

Use the handy envelope (with the old prices) provided and renew your subscription now, before the increase takes effect. Save money now and every month enjoy the best that beekeeping has to offer.

IT'S EASY TO SAVE. RETURN THE HANDY ENVELOPE, OR CALL TOLL FREE WITH YOUR VISA, MC OR DISCOVER CARD HANDY. WE'LL TAKE CARE OF EVERYTHING ELSE!

**1-800-289-7668
CALL TODAY!**

NEXT MONTH

We've got a real treat in store next month. The Walter Swartz Design Group, who did the "Back Yard Label" piece last March is doing another work of art for us - Making Gift Baskets.

If you saw their first offering, and have an inkling to produce gift baskets this year to sell (a *very* profitable idea), or give away you won't want to miss this. It is as informative as beautiful.

The second in The Adee Honey Farms series is next month, too. We'll pick up right where we left off - just arriving at the northern locations in the spring, to getting ready to move south again in the fall. We'll look at supering, honey removal, extracting, equipment, facilities, storage and marketing. Certainly something you don't want to miss. There'll be lots of photos and numbers and how-they-do-it hints.

More? Certainly there's more! "Getting Ready For Winter" - for beekeepers that is, not bees, can be as important as anything you do. Being ready next spring means checking out all sorts of things now. Don't miss our Weekenders Report on Getting Ready.

And, we'll look at pieces of seldom used equipment. Dick Bonney promises an up-close and personal look at some of the regular, but seldom used, and not-so-regular pieces - Next Month.

More? Yes, lots more!

More "Up Close & Personal" honey bee anatomy • More wisdom from Tom Sanford in "Nectar On My Boots" • More from Roger Morse, Richard Taylor, Clarence Collison and the rest.

Next Month - Beauty from Gift Baskets, and lots and lots about bees. Right Here, in November.



MAILBOX

piring authors and/or photographers, here's a golden opportunity. Contact me!

■ Condo Confirmed

Your *Bee Culture* publication of March 1991 had an article by Albert Carl, with Al Loy as developer of "Condos for Bees"

I haven't seen, since the article's printing, any comment by others on it.

The assertion that it produces two to three times the amount of honey as the standard hives was borne out by me.

Two 3-lb. packages of bees with a queen hived in June 1991, produced approximately 180 lbs. by June 1992.

John Schildhauer
Homestead, FL

Editor's Note: We hope Mr. Schildhauer and his bees survived the recent hurricane. Our attempts to contact him by press time were futile.

■ The 'Eyes' Have It!

The small bee has 12,000 eyes.
How can that be: Well, its eyes make it wise:

It knows the land where a bounty lies.
It uses its eyes to give us a prize:
The prize of honey that everyone buys
And then consumes with happy sighs.
It has no peer in other guise;
No others come close in any tries.

When the bee's eyes sadly make their goodbyes
The bee, now at sea, is recalled
though it dies:
Its fields are still bright with brilliant dyes -
The great fields of vision for 12,000 eyes.

The mind's eyes still see the small
bee's own prize,
The great things it saw with its very
own eyes.

Anon.

■ Cage Question

I have been receiving *Bee Culture* for over 10 years and I've never noticed an article on installing queen cages in hives. When I first ordered queens, instead of the Post Office giving me a call as they were supposed to, they were delivered to the house. I happened to be out in the yard when the mail was delivered. When I installed them, I placed the cages, with a wire, in the middle of the hive with 10 frames. There is not enough space to install these cages and expect to have her released. I have since learned that removing one frame gives the bees a better chance to release her. This year, when I ordered new queens, I thought I was ready but when they arrived, they were in a different cage. This new cage is plastic and much different from the old type. I had good success with these new cages but I feel your magazine should write an article, with pictures, in regard to installing these new cages in hives. I understand that these can be installed in a 10 frame hive with no problem.

Kleber J. Minich
Natrona Heights, PA

Editor's Note: An article entitled *Long Live The Queen* was published in the May, 1990 issue, written by K. Flottum and D. Sammataro. It focused on the wood/wire cage, but also explored the biology of queen introduction, and other cage types. It did not, however, examine the new plastic cage many producers are now using. To as-

■ In A Pickle?

This refers to Dr. Taylor's "Bee Talk" in the July, 1992 edition of *Bee Culture*.

Having read what had been said previously in the bee magazines about the idea of recycling jars, I was interested in seeing what the July "Bee Talk" had to say about the matter. Dr. Taylor said "I'm all the time picking up used jars to bottle honey in."

I was sure I had read in *Bee Talk* one or more times previously that Dr. Taylor produced only comb honey.

Then as I read on, in the July edition, whoops, there it was! "I just produce comb honey"

What's up Doc?

Albert L. Phelps
Wilmington, NC

Richard Taylor Replies: That is correct, I produce only comb honey. However, customers at my honey stand often want *both* comb and liquid honey. Therefore, I trade liquid honey in bulk from a neighbor for comb honey I produce, and bottle his honey in the used jars I pick up at recycling centers.

■ Honey Robbers!

I am a beekeeper with 50 hives. I have something to say for your Mailbox page. It's about the O.B. Wisner article on the two queen unit (A Wall Street Beekeeper, Nov. '91). I have been trying this two queen technique. When two queen hives are made up with two frames of sealed honey and two frames of brood and bees from the same hive or other hives from the same yard and put on different hives, I have had the following experience. It seems the older bees, which came along with the

Continued on Next Page

MAILBOX

brood and bees just hatching, take all the honey and carry it back to their parent hive! The young bees and queen are not harmed, but even if you use a top hive feeder so they won't starve to death the same bees will steal that too, and carry it back to their original hive. Can you believe it?

But, I did have good luck when the new colonies are moved to a different yard a couple miles away. I found from my own experience that best results are from bees and brood taken from different yards not the same yard or you can't keep the two frames of honey in the hive.

George M. Christensen
Altamont, IL

■ Easy Clean-Up

I just read your Inner Cover article (August, '92) and felt I needed

to share some information with you.

I have four beehives and although I extract in the garage an awful lot of wax and propolis gets tracked onto my white linoleum kitchen floor.

A product called Citra-Solv has sure saved me hours of frustration. I use a clean *dry* cloth and apply it to waxy goo straight from the bottle and it does get rid of the wax.

It is made by Chempoint Products Co., Division of HPM Corp. 543 Tarrytown Rd., White Plains, NY 10607, 1-800-343-6588.

I found my bottle in a health food store, however I have seen it offered in many catalogues.

Trudy Florence
Leakey, TX

Editor's Note: We've been informed, with both grace and sarcasm, on several ways to remove wax and propolis from surfaces unwanted. It seems several 'tough' cleaners work along with plain old alcohol. So don't get caught, like we did.

■ Political Comments

Your August "Inner Cover" was a timely and appropriate comment on our political problem. I am a hobby beekeeper so the loan program or government subsidies don't directly affect me. But, I do sell honey and the so-called "Free Market" does affect me. Just because you are not a "big beekeeper", don't think cheap imports don't hurt sales. It is time for hobbyist beekeepers to speak out to Washington, and what better time than before an election. There are so many more of us than there are commercial beekeepers so our voice could be heard in larger numbers if we would just rally to the cause.

Bill Holden
Topeka, KS

I read with interest, your article about our corrupt government, in the August issue. I am referring to the last part of the "Inner Cover"

We truly have a government that cares nothing about its role of protecting our lives, liberties and properties.

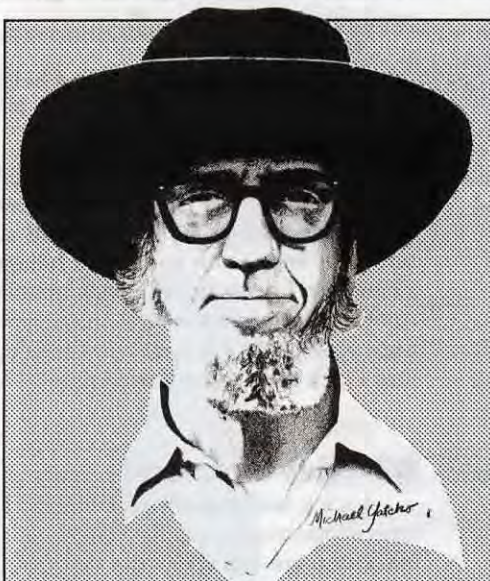

147 Pgs, HdCover, U.S. Post Included

THE BEST OF BEE TALK

Cat. No. X45

\$10.99



CALL
1 800 289 7668
TODAY

THE BEST OF BEE TALK

For over 20 years Richard Taylor has been the best known, and most widely read beekeeping author in the popular press. And for all of those years he has been writing for *Bee Culture*. Now, you can read the best of his over 200 contributions, in *The Best Of Bee Talk*. There's four terrific chapters . .

SPRING – THE PROMISE, looks at swarming and its control, preparing for comb honey production, making splits, scale hives, pickups and the best of seasons.

SUMMER – THE RUSH, covers queen rearing, old bee books, bee yards, animal visitors, making equipment, common myths, diseases, record keeping, round comb honey production and comb equipment.

AUTUMN – THE HARVEST, tells of timing the harvest, removing bees with escapes and other methods, autumn gardens and first frosts, winter preparations, beeswax, making candles, honey quality and even marketing.

AND FINALLY, WINTER – THE BEGINNING, quietly considers the way bees and beekeepers spend that season, and prepare again for the promise of spring.

MAILBOX

All it wants is to dominate the people. It uses the media to convince us that we are free, while our liberties are continually being eroded away. All this is done in the name of democracy. Our country was not set up by our founding fathers as a democracy. It was set up as a Republic. The major difference between a democracy and a republic is that in a Republic, the government has its activities confined within certain parameters by a written instrument called a Constitution.

Alas, our government is constantly violating the Constitution, which our leaders are required to support and uphold. Most of them have never read the Constitution, and certainly don't know what it says.

Paul Ekert
Grantsburg, WI

■ Aged To Perfection

Our organization, Tri-County Beekeepers, a chapter of the Maine State Beekeepers' Association, is trying to locate the oldest active beekeeper in the country. So far our search has turned up Fred Hale of South Portland, Maine, age 102.

Perhaps your readers can help us. If they know of an elderly, active beekeeper, they can send the information (name, age and location) to Tri-County Beekeepers.

We appreciate any help.

Roger Snow, President
Tri-County Beekeepers
Maple, St., Box 627
Stockton Springs, ME 04981

■ Persistence Pays

This is a follow up to my article published in Bee Culture in July of 1987. To recall this to your readers it describes a technique of IPM (Integrated Pest Management) that effectively blocks crawling insects from getting into the citrus trees, yet protects both our bees and the beneficial insects present.

A 4" wide fiberglass band is attached to the trunk of the tree by

securing it to itself. For French snail (*Helix aspersa*) control a saturated solution of copper sulfate is applied. For ants and other insects Lorsban is applied.

At this time I am happy to report that in California, LABEL approval has finally been obtained for the use of Lorsban to be applied to the fiberglass bands. A good number of growers in my district have been using this technique under a temporary use permit and now have permanent label approval. There are still some growers who do not realize that the bands of themselves are not the effective part but merely the reservoir for the materials applied. It should also be noted that to be fully effective the branches and limbs must be trimmed 18"-24" from the ground (this is called skirting).

In our groves this technique is now in its 9th year with no losses to our bees and maintaining effective control of predators with beneficial insects. I strongly recommend this to all who would protect our bees and wish to reduce the use of insecticides.

Dr. Herbert Drapkin
Woodland Hills, CA

Package Bees and Queens
C.F. KOEHNEN & SONS, INC.
Quality and Service Since 1907
Route 1, Box 240, Glenn, CA 95943
(916) 891-5216 or (916) 934-5216

HONEY BEAR LABELS

500 - \$28.00
1,000 - \$50.00

Add \$3.50 per 500 for Postage & Handling

FREE
Imprinting
But Space
Is Limited

Other
2 & 3 Color
Press-On
Labels

Prices Subject
to Change

Order
Now
and
Save!!



CUSTOM LABELS
P. O. box 861
Oconomowoc, WI 53066
Information Only: (414) 567-0392

"BEE ON GUARD"



Limited Edition Lithoprint
by R.C. Anderson

11" x 14", Matted and Ready-to-Frame
Each print numbered and signed by the artist

ONLY 400 PRODUCED!

*Celebrate the fascinating
life of the Honey Bee!*

Send \$35 + \$2.50 for insurance, P & H to:

CRICKET SCIENCE
1611 Shane Dr.
Pocatello, ID 83204

**CHRISTMAS
SEALS.[®]
THE #1 HOPE
FOR THE
#3 KILLER:
LUNG DISEASE.**



**Put them
everywhere.**

**AMERICAN
LUNG
ASSOCIATION[®]**
The Christmas Seal People[®]

Space contributed by the publisher as a public service.

OCTOBER Honey Report

October 1, 1992

REPORT FEATURES

Prices shown are averages from many reporters living in a region, and reflect that region's general price structure. The Range Column lists highest and lowest prices received across all regions, from all reporters.

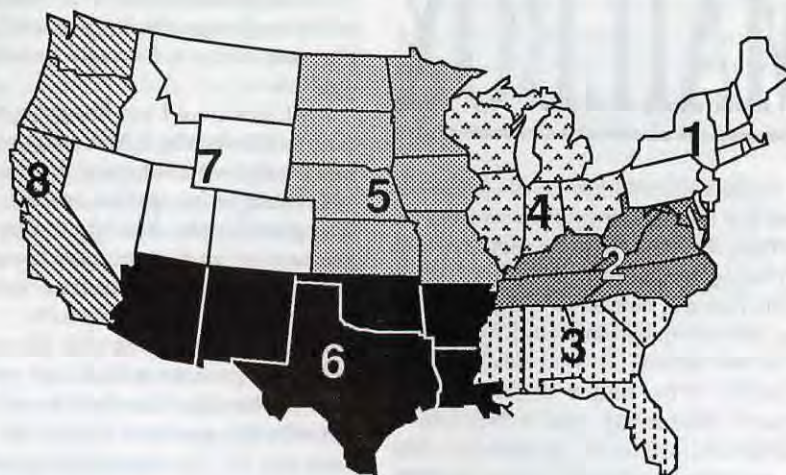

	Reporting Regions								Summary		History		
	1	2	3	4	5	6	7	8	Range	Avg.	Last Month	Last Yr.	
Extracted honey sold bulk to Packers or Processors													
Wholesale Bulk													
60 #Wh.	47.10	47.49	49.47	39.67	39.00	43.50	44.46	44.94	32.40-60.00	44.82	45.18	42.30	
60 # Am.	41.30	41.97	44.50	37.40	38.70	39.63	41.23	43.50	31.80-54.00	40.97	41.47	39.75	
55 gal. Wh.	.647	.605	.606	.570	.543	.581	.571	.635	.46-.79	.596	.574	.576	
55 gal. Am.	.567	.525	.574	.535	.540	.522	.528	.625	.42-.75	.552	.537	.519	
Wholesale - Case Lots													
1/2 # 24's	20.70	23.21	21.69	18.86	16.83	21.26	21.05	21.50	16.50-26.88	20.60	19.87	20.16	
1 # 24's	29.78	30.79	34.50	30.25	27.73	25.43	29.10	27.50	23.50-42.00	29.40	30.28	29.55	
2 # 12's	28.72	28.20	32.90	25.93	25.13	26.83	29.85	29.53	24.00-40.80	28.05	28.37	27.19	
12 oz. Bears 24's	28.48	28.43	31.06	25.67	29.40	27.58	24.78	26.70	22.80-36.00	28.11	26.58	26.48	
5 # 6's	28.84	28.50	31.50	30.33	27.20	30.27	29.64	27.50	26.00-48.00	30.09	31.07	28.35	
Retail Honey Prices													
1/2 #	1.23	1.26	1.35	1.09	.89	1.06	1.07	1.32	.82-1.75	1.16	1.19	1.10	
12 oz. Plas.	1.58	1.63	1.59	1.56	1.28	1.48	1.53	1.45	1.19-1.98	1.52	1.52	1.50	
1 #	1.71	1.88	1.67	1.76	1.57	1.65	1.75	1.64	1.37-2.19	1.74	1.76	1.70	
2 #	3.24	3.14	3.47	3.37	2.68	2.69	3.01	2.78	2.38-4.29	3.07	3.04	3.02	
3 #	3.95	4.36	4.95	4.98	4.00	4.18	4.22	4.45	3.75-6.19	4.33	4.21	4.13	
4 #	5.89	5.10	5.59	5.48	5.55	5.02	5.25	5.12	4.75-6.49	5.34	5.17	5.29	
5 #	7.69	6.35	6.65	6.74	6.10	6.53	6.58	6.14	4.60-8.75	6.56	6.48	6.37	
1 # Cream	2.40	2.37	2.33	1.89	1.75	2.24	2.21	2.00	1.65-3.00	2.13	2.15	1.99	
1 # Comb	2.65	2.55	2.83	2.80	2.99	2.48	2.92	3.08	1.95-3.70	2.73	2.52	2.62	
Round Plas.	2.50	2.95	2.45	2.85	2.65	2.15	2.58	2.48	1.90-3.00	2.40	2.33	2.37	
Wax (Light)	2.83	1.20	1.50	1.25	1.27	1.75	1.58	1.10	1.00-3.80	1.64	1.46	1.29	
Wax (Dark)	1.69	1.07	1.13	1.00	1.11	1.50	1.21	.95	.75-2.25	1.26	1.26	1.09	
Poll./Col.	31.75	20.00	25.00	35.00	25.00	23.00	30.50	31.00	20.00-40.00	29.20	28.87	29.11	

Region 5

Sales seem to be increasing, probably due to the basically cool weather most of the summer. Flip side is that crop is reduced, (in some places very reduced), mostly in the northern two-thirds of the region. Mites a problem, but seem less so, so far.

Region 6

Sales and prices and demand static. Crops range from marginal to marvelous, but generally better than last year because of the rain. AHB quarantine marches on, and is moving west as fast as north. Some are surprised.

Region 7

Prices and sales not as strong as usual this month. Everybody is busy harvesting - not looking at the market just yet anyway. Production good in the north, average pretty much everywhere else. Some pesticide problems showing up more than in the past, unfortunately.

Region 8

Prices just fine over the whole region, along with production. Some bee producers ended up with surplus honey this year - almost unheard of! Southern CA holding its collective breath as AHB knocks on NM & AZ another year at most, some say.

MARKET SHARE

If you're selling honey at a farm stand, provide an indoor shelf sign or try an outdoor "LOCAL HONEY - NEW CROP" sign. At the end of the season you keep the signs. Or split a classified ad: NEW CROP HONEY at BOB'S FARM MARKET.

Give 'em more than they expect.

Region 1

Prices and demand steady. Increases expected (and hoped for) as weather cools. Production across the region average, or a bit lower due to generally cool, rainy summer. Some areas did well, though because of the increased moisture.

Region 2

Sales and prices steady to increasing - significantly in some places. Production, however not as good as anticipated earlier in the season. Bees healthy but weather not cooperating. Demand for local honey should increase.

Region 3

The southern areas are on hold for awhile, until things sort themselves out. Central Florida and up seem average to even better with prices and sales steady.

Region 4

Prices increasing a bit, but sales only steady. Some observers indicate shelf fronts for honey declining as pressure for profit increases from stores. Mite problems increasing as many small scale non-migratory keepers are just learning the evil that lurks within. Crops average to a bit higher, but there are some areas totally empty.

? DO YOU KNOW ?

Producing A Quality Product

CLARENCE H. COLLISON

Now that the foraging season is coming to a close in many parts of the United States and Canada, we will turn our attention to handling and marketing the honey crop. To keep honey in its original condition of high quality and delectable flavor and fragrance, the beekeeper and honey packer must be familiar with factors that govern honey quality. Several beekeeping and processing practices can reduce the quality of the final product. Please take a few minutes and answer the following questions to determine how well you understand the factors that affect honey quality.

The first twelve questions are true and false. Place a T in front of the statement if entirely true and F if any part of the statement is incorrect. (Each question is worth 1 point.)

1. ___ All honeys will darken and lose flavor in time.
2. ___ Honey is not completely ripe until the cells are capped.
3. ___ Sucrose is the predominate sugar found in honey.

Many factors affect the granulation and fermentation of honey. Answer the following questions to determine your understanding of these two processes.

4. ___ The best way to keep honey from granulating is to store it in the refrigerator.
5. ___ Fructose (levulose) is the sugar in honey that crystallizes out of solution.
6. ___ The faster honey granulates, the larger the crystals.
7. ___ Honey is hygroscopic and the moisture content changes in relation to the humidity of the environment in which it is stored.
8. ___ Granulation increases the tendency of honey to ferment.
9. ___ Honey stored below 50°F will not ferment while it remains at this temperature.
10. ___ Honey with a moisture content below 17.1% will

not normally ferment, regardless of the amount of yeasts present.

11. ___ Honey granulation (crystallization) is considered to be a sign of spoilage.
12. ___ Filtering honey will prevent granulation.
13. How would you explain a situation in which an individual's honey granulates and ferments following heating at the recommended temperatures? (1 point.)
14. Fermentation is caused by the action of sugar-tolerant yeasts. What is the source of these yeasts that are typically found in all honeys? (1 point.)
15. Name three reasons for either warming or heating honey. (3 points.)
16. When you see a honey label with a specific floral source, i.e. "buckwheat honey", listed on it, by regulations what does it mean? (1 point.)
17. The main problems encountered in packing honey are excessive moisture, pollen, wax and air. Describe what precautions you would take to minimize the quantities of these materials found in raw honey? (4 points.)
18. Please explain why oval glass jars are preferred to round glass jars for packing honey. (1 point.)
19. What is the function of the sump tank and butyric anhydride? (2 points.)

ANSWERS ON PAGE 574

EARLY DETECTION SAVES HIVES!

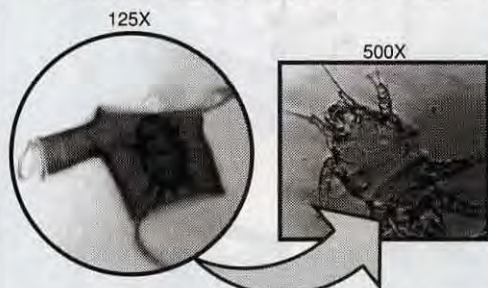

Photos of Tracheal Mite taken with compound microscope courtesy USDA

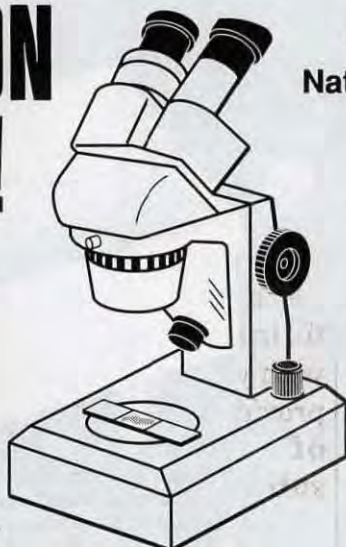

Advantages of Owning a Precision Instrument from National Microscope Exchange...

- Immediate on-site detection eliminates 2 week or longer wait for lab results
- Saves time and money on preparation, shipping and postage
- Multi-purpose 40X dissecting microscopes start at only \$435.00, complete with case - other magnifications available

CALL NOW!

(800) 851-7635



WAX WORKS

JEFFREY L. OTT

Everything You Ever Wanted To Know About Wax Handling Equipment But Were Afraid To Ask

In the past year we've looked at several pieces of honey house equipment. This month we look at the equipment used to process wax cappings. After you've uncapped and extracted all of your frames of honey, what do you do with all of the wet cappings? For many hobbyists, getting rid of cappings poses an even greater problem than unloading honey.

Why would you even bother with the cappings? The quick answer here is money. Beeswax is more valuable, pound for pound, than honey. Even if you do not sell your wax to companies that buy beeswax for candles or other products, you can send it away and have it rolled into sheets of foundation to be used the following year. Additionally, wet cappings contain 50% honey by weight. This too can add to your bottom line.

Beekeepers obtain beeswax in several different operations. One process involves melting old brood comb, separating the wax from the old cocoons, propolis and other debris. The second method involves melting down cappings, produced by an uncapper. The wax produced from these cappings is much cleaner, lighter and more valuable than wax from old brood comb.

The equipment listed in this review will help every beekeeper, of every size. Manufacturers sent their sales information and photographs, but as in the articles on extractors and uncappers, I was not able to set up the equipment and run it side by side. Therefore, use the information in this article to see what is available and make your decision based upon your operation and growth expectations. What is acceptable to the hobbyist with five hives will not be acceptable to the large sideliner

with 500 or more hives. Neither solution will accommodate a commercial operator with thousands of colonies.

Take a look at what is available, read, ask questions, and look around again. Find beekeepers that run the size of operation you do (or plan to) and find out how they handle their cappings and wax, and what equipment they use. Find out if they're happy with it; if they're unhappy with it, or what they'd use differently. Learn from their successes *and* failures and utilize the resources you have before you invest.

One last word here – if you have any unanswered questions, call the manufacturer. These people are friendly and eager to help. As a matter of courtesy have your questions prepared be-

fore you call. Their time is as valuable as your own, so spend it wisely. If by chance you stumble onto someone who isn't reasonable, cross that manufacturer from your list. If they can't be friendly *before* the sale, chances are slim they'll be friendly or helpful *after* the sale. However, I've talked to every manufacturer represented in this article, and have received generous help and advice.

Background

Beeswax is a complicated material. There are over 300 different components combined and secreted by four wax glands beneath the worker bee's abdomen (drones and queens lack these glands). Under normal colony condi-

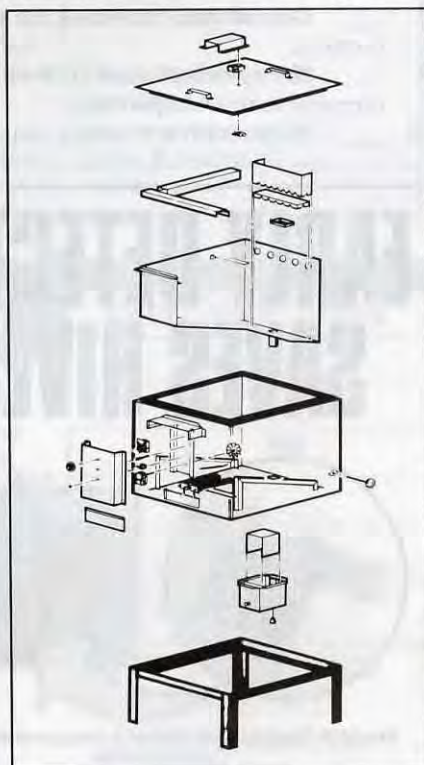

Better Way's machine is one of the multi-purpose units available. Models range from small to very large

Cook & Beals continuous flow centrifuge system is designed for large operations, with continuous flow

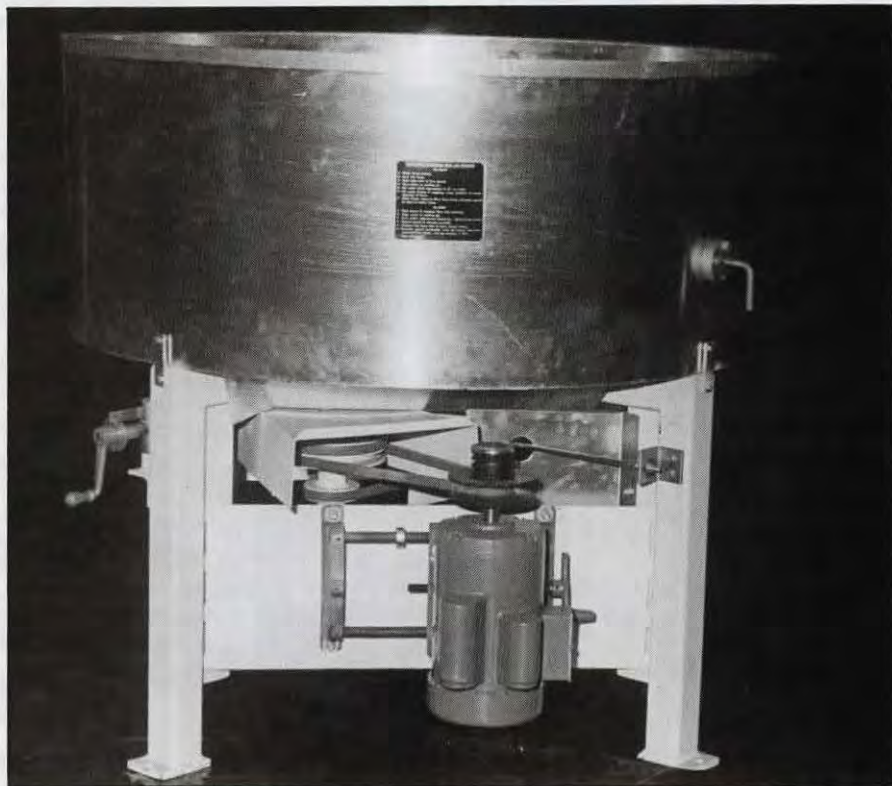

tions, it is the worker in the two to three week age group which produce the small wax scales. Pure beeswax is white. However, it is usually seen in a shade of yellow because of the staining of pollen, propolis and other debris from the beehive.

Wax, like honey, can be darkened through contact with different metals. Iron, brass, zinc and copper will darken wax if it is heated in containers made of these metals. White stainless steel is the preferred metal of choice when pro-

cessing wax, but aluminum and galvanized metal work just as well. However, if galvanized metal is scratched, the resulting contact of wax to iron will darken the wax and honey.

Keep this in mind when purchasing used equipment. Earlier brand melters were heated by steam pushed through copper pipes. Recall copper will darken both honey and wax. Additionally, the heat generated from steam pipes is too great and will damage the honey.

The Affects of Heat

Wax melts between 144 to 150°F (62 to 66°C). When heated a honey/wax mix is not uniform. Melted wax floats on top of honey, but the honey heats up, too. Care is required not to overheat the entire load, especially if the honey is for human consumption.

Honey is a delicate substance. It carmelizes and burns easily. A small amount of burned honey will ruin the flavor of an entire batch. Use the mini-

Continued on Next Page

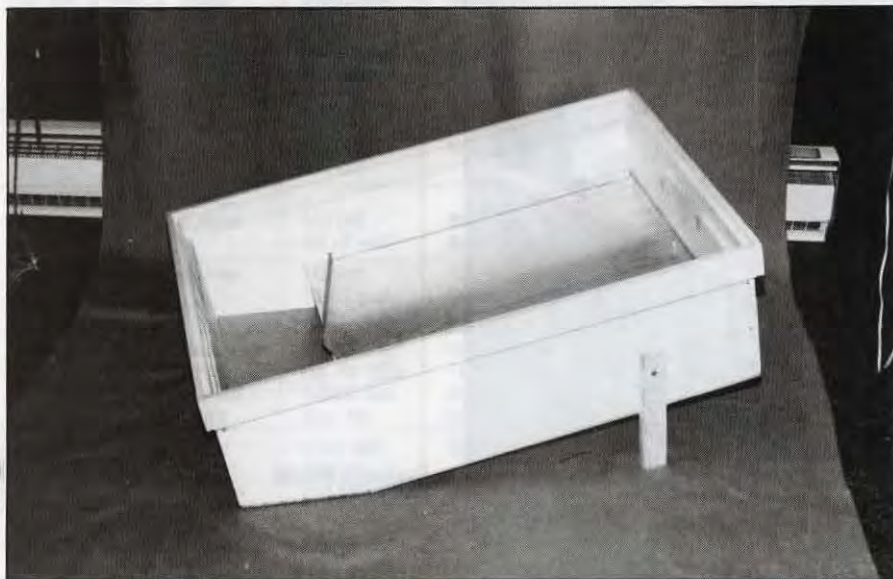

A typical solar wax melter. Reliable, inexpensive and easy to use.

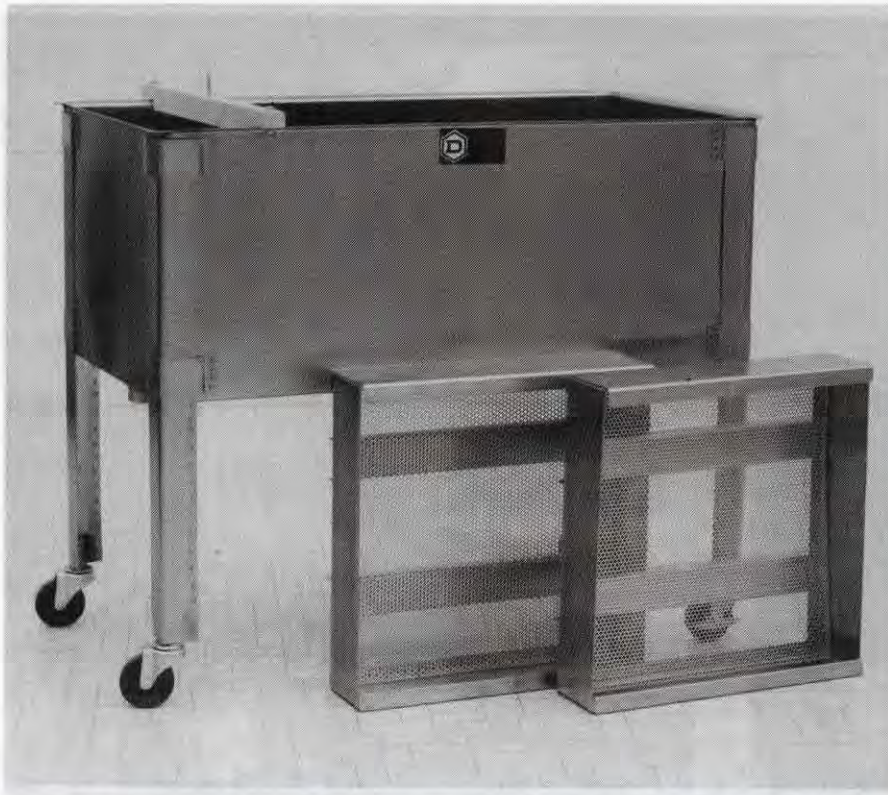

Dadant's Model
M00370 cappings
tank and baskets.

WAX ... Cont. From Pg. 547

mum amount of heat in any wax melter to do the job, and check the temperature often. Additionally, adding heat to honey and wax will have a tendency to darken both. Honey can darken up to 15 points on the Pfund grading scale by overheating.

If you plan on exporting your crop, you must consider one other aspect of heating honey. HMF (hydroxymethylfurfuraldehyde) is a natural component of honey constantly being pro-

duced by the chemical breakdown of fructose. The HMF level increases over time, or if the temperature honey is subjected to during processing is high. Because of these factors some countries use the HMF level as an indicator of honey quality.

The entire subject of wax, honey and heat is complicated and sometimes conflicting depending on the source of your information. Eva Crane, in her book *Honey*, sums up the matter of

heat, wax and honey in a few short words, " (as) little heat as possible should be applied to honey, and for as short a time as possible."

Types of Melters

Solar Extractors A hobbyist and many sideliners will most likely use a solar extractor to melt down the wax and separate honey. Solar extractors are not extremely efficient in recovering wax from cappings. Even under the

Continued on Page 550

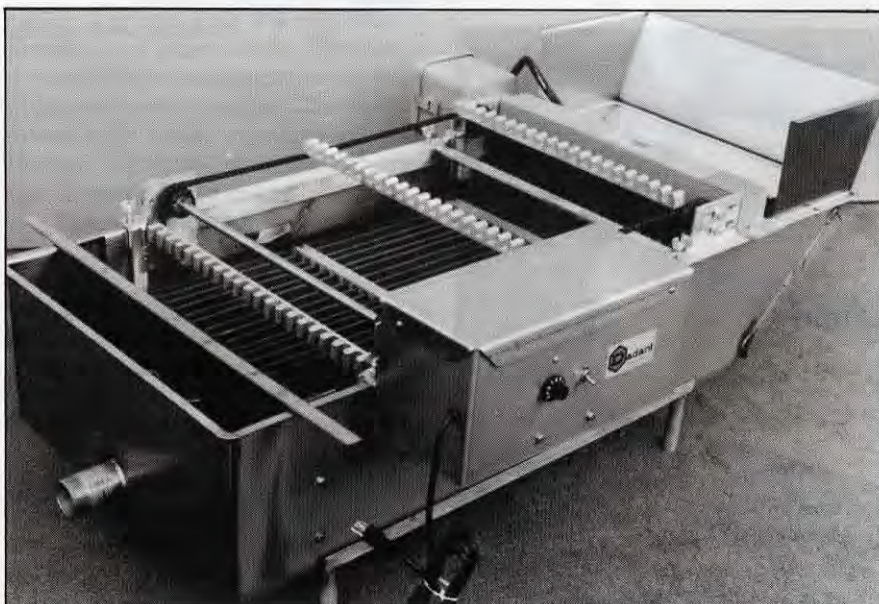

Dadant's Model
M00553 -
Electromelt with
available slum
rake attached.

Manufacturer & Equipment	Process Type	Electrical Requirements	Building Material	Number of Colonies ¹	Flair ²	Capacity	Dimensions (LxWxH)	Price	Shipping Weight	Notes
BETTER WAY WAX MELTER										
15F	Forced hot air	1000 watt 120v; 15amp	Insulated Galv.	100	Y	30 gal. tank 15 frames	30"x25"x22"	\$545 galv. \$630 stnls.	69 lbs.	stand incl.
20F	Forced hot air	1000 watt 120v; 20amp	Insulated Galv.	250	Y	40 gal. tank 20 frames	30"x33"x24"	\$620 galv. \$705 Stnls.	120 lbs.	stand incl.
30F	Forced hot air	2-1000 watt 120v; 20amp	Insulated Galv.	500	Y	50 gal. tank 30 frames	46"x27"x24"	\$645 galv. \$740 Stnls.	160 lbs.	stand incl.
40F	Forced hot air	2-1000 watt 240v; 30amp	Insulated Galv.	800	Y	65 gal. tank 40 frames	46"x33"x24"	\$775 galv. \$885 Stnls.	180 lbs.	stand incl.
50F	Forced hot air	2-1000 watt 240v; 30amp	Insulated Galv.	1,000	Y	75 gal. tank 50 frames	46"x40"x24"	\$845 galv. \$975 Stnls.	250 lbs.	stand incl.
COOK & BEALS, INC.										
Float-Spin Honey-Wax Separator	centrifuge cont. flow	1-1/2 HP 220v mot.	Aluminum	commer. sized oper.	Y	Handles up to 3,000 lbs./hour	42" high 44" wide	\$6300	550 lbs.	
DADANT & SONS, INC.										
Solar Wax Melter (M00501)	Sun/Solar	N/A	Wood	any #	N	Small Amts of wax/burr combs	24"x19"x6"	\$52	25 lbs.	You purch. cover
Liquidator (M00394)	Immersion	1800 watt 120 volts	Stain. Steel	1-100	N	1-3/4 cu. ft. 27-200 frames/batch	14" diam. 24" deep	\$370	35 lbs.	Multi Purp. 4 in 1
Mini Melter (M00549)	Brand	110 volt elec. melt. grid	Stain. Steel	50-500	N	Handles up to 250# honey/hour	36"x12"x8-1/2"	\$415	30 lbs.	
Mini Melter-water jacketed (M005491)	Brand	110 volt elec. melt. grid	Stain. Steel	50-500	Y	Handles up to 350# honey/hour	N/A	N/A	N/A	Avbl. 1/93
Electromelt (M00553)	Brand	6900 watt 240v elec melt. grid	Stain. Steel	150-up	N	Handles up to 600# honey/hour	54"x26"x12"	\$2,150	240 lbs.	
Electromelt, water jacket. (M005531)	Brand	6900 watt 240v elec melt. grid	Stain. Steel	250-up	Y	Handles up to 1,000# honey/hour	54"x26"x15"	\$2,474	350 lbs.	
Electromelt, water jacketed, slum system (M005531&M00548)	Brand	6900 watt 240v elec melt. grid	Stain. Steel	300-up	Y	Handles up to 1,500# honey/hour	54"x26"x15"	\$3,369	420 lbs.	
Electromelt, water jacketed, slum rake system, plus auger slum removal (M005531 & M00548 & N/A)	Brand	6900 watt 240v elec melt. grid	Stain. Steel	300-up	Y	Handles caps. from up to 1,500 lbs. of honey/hour	54"x26"x15"	N/A	N/A	Avbl. 1/93
FAGER CORPORATION										
King Melter	Heated wtr/jack	2-4500 watt 230v; 50 amp	Alum. with 1/2" insul.	1,000 - up	Y ³	30 barrel/day	54"x48"x46"	\$3,795	217 lbs.	
WALTER T. KELLEY CO.										
Cappings Melter Wax Sep. & Heat. (#198, 199, 104)	Double Boiler	1,500 watt 110 v; imer. heater	Stainless Steel melt. Galv. sep.	15-40	N ⁴	Holds approx. 15 lbs. caps.	19" diam. 14-3/4" deep	\$153	46 lbs.	
Jumbo Cappings	Radiant heat & steam/wtr.	2-3,000 watt infra. lamps 230 volt	SS Tank Copper warmers	300-up	N ⁴	Up to 20 barls./day	10"x24"x10"	\$1,425	425 lbs. (melter 190 #)	Attach under Cowen
Kelley's Wax Press	Press	5,000 watt imer. htr. 230 volt	12 gauge steel plate	N/A	N	N/A	24"x24"x30"	\$340 \$33.50 heat.	300 lbs.	
MAXANT INDUSTRIES, INC.										
Series 1200-JR Spinner	Spinner	110 volt, 1/3 HP mot.	Stainless Steel	up to 100	Y	Holds 5 gal. of caps.	20" diam. 32" high	\$845	150 lbs.	
Series 1200-SPNR Caps. Spinner	Spinner	110 volt, 1/2 HP mot.	Stainless Steel	up to 500	Y	Holds 15 gal. of caps.	30" diam. 30" high	\$1,545	300 lbs.	uncap. mounts above.
Series 2500-4 Cappings	Rad. Heat Heated Wtr/jack. Water	2-1,100 watt rad. htr. 220v 1-2000 watt imer. hts.	Inner SS Tank & hood ply. btm. & sides	up to 1000	Y	Holds 25 gal. of caps.	4"x44"x22"	\$1,775	350 lbs.	
Series 3900 Wax Process. Tank	Water Bath	1,500 watt imer. htr. 110 /220 volts	Stainless	up to 1000	N ³	Holds 60 lbs. of wax	15" diam. 24" high	\$345	45 lbs.	Multi 4 in 1

Notes:
 1. Estimate by manufacturer, your results may vary. This is for rough estimate only.
 2. Is the equipment compatible with chain/flair uncappers; Y for Yes, N for No.
 3. Most honey must be removed from cappings prior to loading
 4. No data available from manufacturer.
 N/A = Information not available or not applicable.



Kelley's cappings melter with immersion heater. Wax separator pail and stand shown also.



Maxant's #3900 wax processing tank.

WAX ... Cont. From Pg. 548

best conditions, solar extractors recover 75% of the available wax in cappings and even less from old brood comb.

Solar extractors can be bought or made at home in any size using a variety of readily available materials, including scrap lumber and glass. Building plans are available in several books and extension publications.

The wax produced by the solar extractor is considered high quality, however, any honey produced should be fed back to the bees or disposed of. Because of the extremely high heat generated by a solar extractor, never mix or otherwise sell this honey for human consumption.

Brand Melters In 1935, W.T. Brand, a beekeeper from Nebraska designed and built the Brand Cappings melter. The method of heating has changed from steam carried through copper pipes to an electrical grid, but the operation and appeal of this unit have remained the same.

Cappings are either dropped directly into the unit from the uncapper or are carried from the uncapper along a conveyor belt or auger. The unit is set up with the heating grid sitting at a height that is above the honey outlet, but low enough to be kept submerged in

the cappings. Remember, wax floats on honey when melted. During operation the wax melts and drains out one outlet (upper) and the honey from another. The beekeeper ends the day with the wax and honey separated.

There are several variations on this type of wax melter. However, these units do not use an electrical grid to melt the wax, but radiant or infrared heaters. Additionally, the bases of these units can be heated by a hot water jacket. As with the traditional brand-type melter, honey flows from one outlet and wax from another.

Spinners/Whirl-drys These units work on the same principal as a cream separator. Cappings with honey fall into the tank directly from the uncapper or via a conveyor or auger system. The tank contains a smaller rapidly revolving tank inside a larger one. Cappings and honey are flung to the walls as the inner tank spins. The honey is forced through the small openings of the inner tank and are collected in the outside tank. The moist cappings are then scraped from the inner tank manually or by an automatic revolving knife in the unit.

The moist cappings are then processed in a melter. The honey drains into a sump where remaining wax par-

ticles can be removed. From the sump honey is fed to a holding tank where air and minute wax particles can rise and be skimmed out.

Multiple Purpose There are a couple of units available not easily classified. At the same time they have the ability to perform several functions. The Better Way Wax Melter uses an electric heating element that does not come in direct contact with the honey or the wax, and two fans to circulate the heated air inside an insulated box. The heat can be thermostatically controlled from between 100° and 350°F. The unit can either melt cappings and separate the honey from the wax, liquify crystallized honey, melt down old brood comb, or sterilize wooden ware.

Dadant makes a multiple purpose unit that can function as four units in one. Depending on how you set it up, it can function as an uncapping/cappings drain tank, a one-can liquefier (of 60 pound containers), a wax melter or a 175 pound bottling tank.

Finally – the wax press. This is the recommended method of retrieving wax from old brood comb and slumgum (the brown/black residue from cappings processing, or brood comb melting). It can

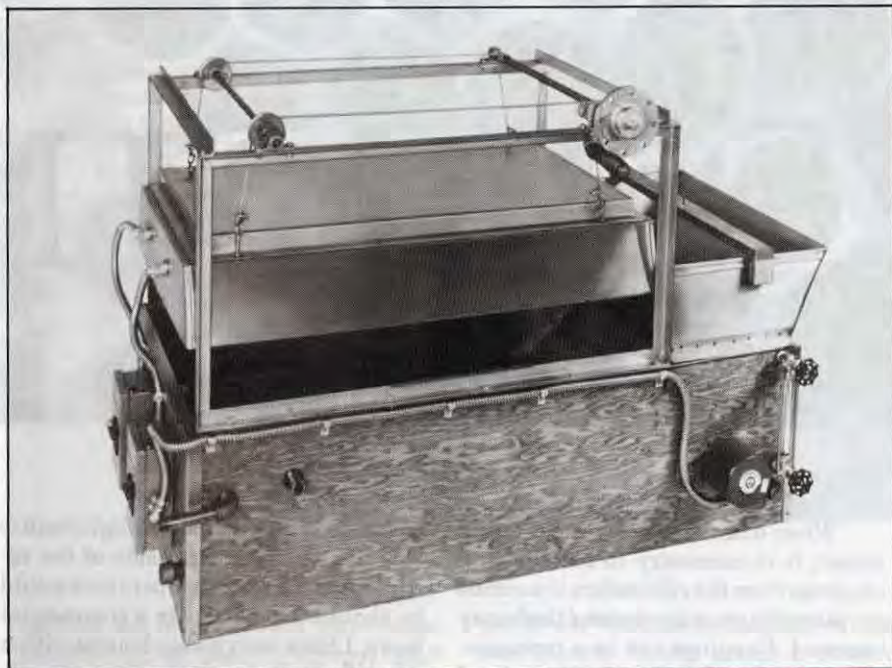

Maxant's Honey/cappings separator. Metal/wood construction is unique.

also be used to process dry cappings. First the cappings or old brood combs are soaked in hot water and placed in burlap bags. Under pressure of the press, heat, and hot water the wax is separated from the old cocoons and other debris of old brood comb. The process is slow (anywhere from 30 minutes to 10 hours), but extremely effective. In the book *Beeswax*, Cogshall and Morse report that a properly operated wax press should recover all but 0.5 to 2.5% of the available wax in slumgum.

Conveyors and Augers Most beekeeping operations depend on the "Armstrong" method of moving the cappings to the processor. Larger operations, with barrels of cappings to deal with each day place conveyors or augers under their uncapper to move the cappings to the melter.

Final Thoughts

Most of the equipment listed here is designed for sideliners or large operations. Brand melters work best with a steady and constant supply of cappings to properly maintain wax and honey temperatures. If you process too much or too little cappings, or are inconsistent in production you are going to run into problems.

Another aspect to consider is what type of uncapper you use. Chain Flail uncappers literally pulverize the cappings to fine pieces. This may cause problems for a wax melter if it is not designed to handle such a fine mixture

of wax and honey. The chart shows if the wax melter can handle cappings from a chain-flail uncapper.

Even if you are able to maintain a constant output of cappings you still run the risk of overheating, burning and ruining the honey. For this reason I cannot recommend mixing honey reclaimed by melting cappings with honey to be bottled. Overheated honey will darken and may effect the taste of the final product. The best use of this honey, if it is maintained is to sell it to bakers or feed it back to the bees. The taste of burned honey will spoil many future sales. Be very fussy.

For a small scale beekeeper the best bet is a solar extractor. It is inexpensive and can be made at home at a near-nothing cost. The best bet, I think for a larger hobbyist, would be a multiple purpose melter. You run the same risk of burning honey as you do in a brand melter, but a multipurpose unit can be used in other areas of your operation as well, such as melting down comb, liquifying crystallized honey and even sterilizing diseased equipment.

My reasoning for smaller beekeepers deals with cost. If you are not big enough to report your beekeeping business to the IRS, why would you tie up \$400 or more in equipment used only a couple of days a year? If you are a hobbyist or small sideliner purchasing equipment with more than one use makes very good sense.

Over the past year I've taken a look at the major pieces of equipment avail-

able (extractors, uncappers, and cappings processors). After looking at all of the requirements for the equipment I am amazed at the systems available to a beekeeper of any size. In fact, there are so many variables it can be very confusing. We hope these articles help identify the equipment available and their merits and limitations.

New equipment is introduced almost every year, too. Dadant has a plastic extractor not available when we published the Extractor article. These articles will be revisited on a periodic basis. Send your suggestions, comments (both good and bad). Perhaps there is more equipment that should be grouped and looked at. Let me know. ☺

SOURCES

- | | |
|---|---|
| Better Way Wax Melter
116 11th St. SE
Altoona, IA 50009
(515) 967-4952 | Fager Corporation
1220 Grignon St.
Green Bay, WI 54301
(414) 432-7187 |
| Cook & Beals, Inc.
P.O. Box 220
Loup City, NE 68853
(308) 745-0154 | Walter T. Kelley Co.
3107 Elizabethtown Rd.
Clarkson, KY 42726
(502) 242-2021 |
| Dadant & Sons, Inc.
Hamilton, IL 62341
(217) 847-3324 | Maxant Industries, Inc.
28 Harvard Rd.
P.O. Box 454
Ayer, MA 01432
(508) 772-0576 |

CAPPINGS

ROGER MORSE

When a beekeeper produces liquid honey, it is necessary to cut the wax cappings from the cells before the combs are placed in an extractor and the honey removed. Cappings can be a nuisance. When combs of honey are uncapped with a knife, or even a machine, ten to thirty percent of the wax and honey are cut from the tops of the cells. Fortunately, there are a variety of ways to separate cappings and the honey. Unfortunately, most methods require time and effort, but the wax and honey recovered can be profitable. It is a good idea to find the best way possible to do this. Here are a few.

Draining

Probably the easiest way to dry cappings on a small scale is to let them fall into a wire bottom basket as the combs are uncapped. The basket(s) of cappings are then placed in a warm room for 24 to 48 hours and the honey allowed to drip slowly from them into a catch basin or tank. If you have between one and ten supers to uncap, a small basket a foot or so square is large enough. I know commercial beekeepers who uncap tons of honey and use large wire bottomed tanks as much as four feet wide and eight feet long for the same purpose. It is best to use wire on the bottom of the tank that has three or four wires per square inch in each direction.

The draining method definitely works best if you place the basket in a warm room or container while the honey drains. On a small scale, a second hand refrigerator works well. A thermostatically

controlled 100 watt electric light bulb is sufficient to heat the inside of the refrigerator. The best temperature would be about 90 to 95° F. On a commercial basis, I have seen honey houses with a specially heated room for this purpose. The large, wire-bottomed strainer, with a tank underneath, is usually on wheels and can be wheeled into the room.

“Cappings wax is the most beautiful and most expensive ‘chore’ you’ll ever have in beekeeping.”

A cappings press

It is possible to place cappings in a press that looks much like a cider press, and using a screw, press the honey from the cappings. Don’t use a cloth to hold the cappings like those used for ground up apples that are to be pressed. Instead, the head of the press runs down into a wire and metal or wooden basket

that allows the honey to flow out through the sides. A cappings press will sometimes capture small bubbles of honey in the cappings. Presses work best when the honey and the wax are warmed before pressing. I much prefer to uncap combs of honey that have been kept in a hot room prior to being extracted. If the temperature of the hot room is 85 to 90° F. the combs will uncap easier and the cappings will drip-dry faster.

Extracting cappings

Many old-time extractors had internal baskets. These were made in such a way that three or four pieces of triangularly-shaped metal could be placed on the bottom of the comb basket to make it a tank, and cappings can be placed in the basket for extracting. The cappings will be reasonably dry after running the extractor 20 to 30 minutes. However, removing the cappings from the inside wall of the extractor basket is difficult and messy. I have used this technique many times and I don’t like it at all.

A few bee supply manufacturers have made extractor-like machines, called whirl-drys, for the express purpose of drying cappings. A whirl-dry is nothing more than an extracting basket. In some models, the operator allows the cappings to fall directly into the whirl-dry, which is kept running at a low speed while the combs are being uncapped. At the end of the day, or after

uncapping a number of supers, the machine is speeded up and the cappings dried as they would be in an extractor. I don’t care for this method either, as it is difficult to remove



the cappings from the whirl-dry, too. They stick tightly to the walls of the whirl-dry and must be pried off with a hive tool or a small shovel.

Washing cappings

Sometimes you'll hear people recommend that water be added to the cappings and the honey washed from them. The honey-water mixture may be used to make mead or honey vinegar. You need a wire-bottomed tank for the wet cappings to fall into, to drain, and a place for them to dry. This method hasn't any special advantages nor is it easier than any other method.

'Bee' cleaned

I have almost always allowed bees to rob out wet cappings after they have drained dry. And, almost always when I have said or written that, there has been an outcry and people complain that it is a way of spreading American foulbrood and perhaps other diseases. They are correct. However, robbing is the most efficient method of removing the last bit of honey from cappings or combs. The bees do the work.

When I lived in the Hudson Valley of New York state, I carried my cappings to a remote location in the Catskill Mountains where there were no bees. I kept one or two colonies there for the express purpose of robbing and drying cappings and supers. I prefer to let bees rob out supers in the fall and to store the combs dry, rather than wet with honey. I don't like to handle wet supers in the spring and there is also a small danger that wet supers may stimulate robbing in the spring. Where I live now there is no remote area where there are no bees so I let the bees rob out the cappings in an out yard where there are no people nearby and the robbing bees will be no problem. I am very much aware that there is a danger of spreading disease in this manner. I check for disease frequently and treat colonies as necessary.

Bees cannot rob all of the honey from cappings on a solid platform, especially from the bottom of the pile. However, if you have a basket or box with a wire bottom so that the bees may lick honey from the underside, as well as the topside, they may do so with ease depending upon the quantity of cappings in the box. The reason for suggesting that a box used to drain cappings have a coarse wire on the bottom, three or four wires per square inch, is that the bees may move through the wire to

Whenever you're removing cappings, be sure you have something to catch the cappings, and let the honey drain out. This mesh bag is one example.



remove the honey. If the wire basket contains a great quantity of cappings, it may be necessary to shovel them over to expose the honey in the center of the pile. Cappings that are robbed dry by bees may be shoveled like sand into a box or bag for shipment to a renderer or loaded into a wax press or solar wax extractor with ease.

rendered. Wax moths and other noxious insects seldom attack a block of rendered beeswax, or cakes of cappings or old comb refuse taken from a wax extractor and allowed to harden into a compact mass in a container. Old combs, of course, are quickly attacked by wax moths and other insects. Honey recovered from a solar wax extractor should be returned to bees for feed or destroyed because the high heat in the box makes it unsaleable.

“There is no simple way to harvest this crop, but there are lots of ways.”

Solar wax extractors

One method of recovering high quality wax from cappings is to use a solar wax extractor. However, solar wax extractors are not efficient. The best built solar wax extractor, even if it has an inside temperature of nearly 200° F, will recover only 75 percent or less of the beeswax in cappings and even less from old comb. The residue from a solar wax extractor should be saved, though, and when you have enough, take it to be

Other methods

Commercial beekeepers who process tons of honey often use very large settling tanks. The wax cappings rise to the top of these and are periodically skimmed off and allowed to drain dry before being rendered or robbed. There is also a commercial centrifugal force machine that does an excellent job of separating the cappings from the honey. However, even these cappings are wet and must be processed further.

Yet another method of handling cappings is to use a Brand melter or some other device that melts the beeswax while it is still in contact with the honey. Brand melters are popular because at the end of the working day the cappings have been processed and there is no further work necessary. However, the very best Brand melter, operated under optimum circumstances, will burn and darken the honey somewhat. Tests that I have run show that the honey that is processed through a Brand melter is darkened about 15 points on the Pfund color grader. This is not very much but insofar as I am concerned it is too much to be tolerated.

Continued on Next Page



Solar wax melters work well, but leave about 25% of the wax uncollected. They also work well for removing wax and propolis from equipment – like excluders.



Soaking cappings in a bucket of water removes most of the honey. The water can be used for mead or vinegar, and the cappings are fairly clean. Be sure and drain well.

CAPPINGS ... Cont. From Pg. 553

Conclusion

There is no good, simple, or easy method of processing cappings, especially on a small scale. Allowing the cappings to drip dry for 24 or 48 hours is the cheapest and easiest method.

Solar wax extractors are great for recovering a high quality beeswax, especially if you want to make candles or otherwise use the wax. But they too, are far from perfect.

Nevertheless, cappings wax is the

highest quality wax you can obtain. It has the nearly perfect 'lemon yellow' color sought after by wax judges, candle buyers and other 'fussy' customers. It pays to go through all the trouble involved. ☺

HEALTHY BEES

It's not always easy - But we can help.

BEE-PRO®

The complete high protein pollen substitute.

BEE-PRO® supplies the proteins, lipids, minerals, and B-complex vitamins honey bees need to produce larval food. It is specially formulated for the commercial beekeeper who is feeding syrup. BEE-PRO® is free of all contaminants unlike natural pollens which may contain pesticide spray drift and disease carrying bacteria (foulbrood). It can be used for building colonies in late winter or early spring, to prepare for pollinating, and to maintain and/or increase brood production prior to and after honey flow.

Terra-Patties®

Terramycin Extender Patty Bulk Mix and Pre-formed Patties

Terra-Patties® used for the control of American Foulbrood caused by *Bacillus Larvae* and European Foulbrood caused by *Melissococcus Pluton* sensitive to oxytetracycline. Terra-Patties® use an exclusive process which assures a positive attachment of oxytetracycline to each grain of sugar. This helps prevent separation of oxytetracycline and the palatable carrier (sugar) and this assures that every patty contains the proper dose of medication. Each six oz. patty contains 1000 mg of oxytetracycline equivalent to five-200 mg dustings of terramycin powder and sugar mixture.

Mite-a-Thol Menthol

Pre-pack or 55# Box

Mite-a-Thol Menthol is nationally approved for the control of Tracheal mites. These mites infest the trachea or breathing tube of the honeybee. Causing bee death and hive dwindling. Treatment for Tracheal mites is most effective in the Fall immediately after taking off honey and in the Springtime when the weather is warm enough for the menthol to vaporize. It is essential that bees that are going to be wintered be treated in the Fall. The recommended dosage to treat a hive is 50 grams or 1.8 oz. per hive for a period of at least 21 days.

MANN LAKE SUPPLY

County Rd 40 & First Street * Hackensack, Mn 56452

Call Toll Free 1-800-233-6663

N · E · C · T · A · R



In the quest for the perfect feeding method, consider the candy board as an alternative to either sugar syrup or dry sugar. The candy board is simply a plywood cover with a wooden rim attached. The rim can be anywhere from 3/4" to 2" deep; the resultant cover will hold from two to five pounds of candy.

Candy boards are best used to feed bees during the colder parts of the year. However, the weather must be warm enough that the cluster can break for at least part of a day to reach the sugar. Humidity is created inside a colony when the bees warm the cluster, and when the rising moisture-laden air contacts

heat source and adding cream of tartar, cool to 125°F, then stir until cloudy and pour into the board. When cool the candy is rock hard. A simpler alternative is to wet the board, pour in dry sugar, just barely dampen the mixture and allow it to dry for several weeks. Nails driven through the rim before the sugar is added will help keep the cake in place, sort of like rebar in concrete.

A big advantage of the candy board is that it can be made up ahead of time and stored until needed. Feeding then is simply inverting the candy board over the top bars sugar side down. If you use telescoping covers the outside di-

CANDY BOARDS

DR. TOM SANFORD

the cooler candy board, the candy become softer and easier for the bees to eat.

Constructing a candy board is straightforward. Preparing the candy, however, often calls for experimentation. One recipe calls for heating a super-saturated solution of sugar (12 pounds sugar; 1-1/2 pounds honey; 1-1/4 quart water; 1/4 teaspoon cream of tartar) to 238°F. Others recommend heating the mixture to 300° to 310°F. After removing the mixture from the

mensions of the board should be the same as an inner cover. If you use migratory covers, however, the candy board should completely cover the top super. Robbing is minimized because there is no possibility of spilling sugar syrup during any part of the process and the board is difficult or impossible to reach



ON · MY · BOOTS

from the main entrance – for a robber, that is.

At first glance, the advantages of the candy board are appealing. However, only when you see the fruits of using the candy board mature within your own management style should its use become doctrine.

Candy boards can be used in emergencies, for long term feeding and in situations where other feeding equipment just isn't practical (or possible). Consider a candy board this fall. ☐

WENNER HONEY FARMS, INC.

Package Bees • Queen Bees

Rt. 1, Box 284
Glenn, CA 95943
(916) 934-4944



Labels

HONEY BEAR LABELS
We have a large selection starting from \$26.00 = 500 — \$48.00 = 1000 + S&H
FREE!! U.S.A./Granulation Labels with each order.

Manufacturers of all types of Pressure Sensitive Labels

For sample of all our labels send \$1.50

R.M. FARMS P.O. Box 684, Dearborn Hts., MI
48127-0684 Ph. (313) 722-7727

Draper's Super Bee Apiaries, Inc.

RR 1, Box 97 • Millerton, PA 16936-9737
(800) 233-4273 • (717) 537-2381

Come visit us in scenic Northern PA

We enjoy giving tours • Non-beekeepers welcomed!

Your Source For

- Shippable Gift Honey
- Candles • Maple Syrup
- Honey Sweetened Apple Butter

Special Item:

Full line of bee-related videos in stock – New Bear Fence Video available.

Call for listing.

Need Information:

Give us a call – if we cannot help, we will give you the name of someone who can!

FALL FEEDING

A Primer

I've just come in from my backyard where small clouds of Painted Lady butterflies are streaming across the valley, headed due North to their summer pasture. They are coming up from Mexico and are more than four weeks early. Like last year, the winds have blown them off course.

Normally we do not have them come through Utah, but this El Nino thing off in the Pacific has been playing havoc with the weather on the West Coast and, from what I understand, the whole United States.

As I watched the small orange and black butterflies land on my Forget-Me-Nots or visit my blooming primroses for a sip of nectar, I was worried. Last year they came and we had a bad year. My thoughts turned to the fall-time and how to insure my hives would be well supplied with food for the winter that will surely come in November. Eventually we will have a normal, cold, snowy winter and I intend to be ready for it.

My first thought was to really re-

double my efforts on being careful on my supering and be real conservative.

Feeding bees in the fall or spring is not my favorite pastime and I try like everything to avoid it with good management. So before I talk about fall feeding, I would like to tell you how to avoid having to do it.

SUPERING The major factor in



A glass jar used to feed. Gallons are best because you don't need to refill them as often. Colony opening not required.

SAVING HONEY Saving honey for feed is smart. Honey is better for bees and when you use it you are not supporting the competition – the sugar industry. I mean really, how much honey does C&H sugar buy from you? Why should we support their industry with our dollars. They are already feeding every American over 100 lbs. of sugar

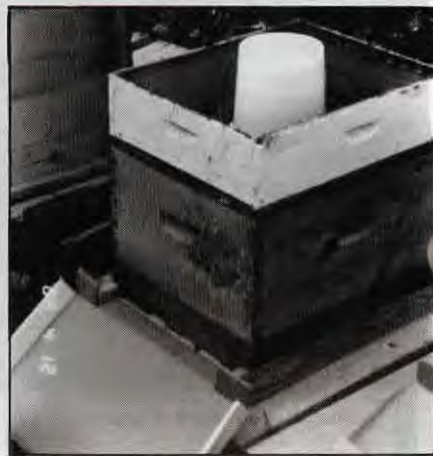

Plastic pails, with screened feeding holes are excellent. They don't break, hold a full gallon and have a hundred uses. Colony opening not required.

O.B. WISER



whether your bees will need to be fed or not is how you super the bees — especially the second or third super. I make it a practice not to put any supers on a hive with a super already on it *unless that super is nearly totally filled and there is nectar coming in for at least two weeks*, and there is no brood in it at all. Top supering is much safer, and much easier than bottom supering — it's the only way to go.

The next thing is to know *about* how much honey your area normally makes and figure how many supers that is. I figure 45 lbs. of honey per full depth super and 32 lbs. for the 3/4 depth shallow. Sure, they hold more honey than that, but that is a conservative average. Make sure you do not over super and you will keep fall feeding to a minimum.

each and every year and they are working on ways to increase that. *I keep one to 1-1/2 frames of honey for each hive.*

REALITY BEEKEEPING No matter how hard you try, if you have more than a few hives some will invariably be short on honey. How to tell? I have been in beeyards from coast to coast and this is the number one question that seems to be a mystery to most new beekeepers.

If you're really into it, buy one of those scales and ask what they are *supposed* to weigh in October. Barring that, what is the manipulation you or your wife or son can do to make sure you have bees to take care of the next spring?

HEFTING Is the number one technique for telling the winterability of a beehive. It kind of requires that your beehive be on somewhat level ground and that you can tip it up from the back

■ GLEANINGS IN BEE CULTURE

or front.

The process is very simple. However, you have to know what *relative weight* is going to be enough. This requires that you look into a hive and find one with a full super of honey in the top position and heft that hive first and get a real good idea of how it feels.

You simply walk up to the back (or front) of the hive and grab the handhold (hopefully a cleat) put your left shoulder near the hive and grab the handhold with your left hand and tilt the hive up to a 45° angle. Do it several times until you can remember what it feels like. Then go to the next hive and determine if it weighs more or less. If a lot less,



Internal feeders. Sometimes called 'division board' feeders. Close to cluster so easy to feed and eat - but you need to open the colony to add syrup.

mark the hive and then to satisfy yourself, look into the top super and see how much honey it does or does not have.

Hefting hives is an art and must be practiced. When I do a yard of bees I always do the first three or four hives over to make sure I have not been fooled because I was just starting.

FEEDING BEES If you were wise you already have supers of capped honey to replace empty frames with, because you kept some back when extracting. You go out on a warm day in October and on one trip to a hive, *being careful to keep everything under cover to stop robbing*, and you're done. You can go deer hunting and sleep well when the snow flies knowing that your bees are cared for.

But let's say you need to feed sugar syrup. The best delivery system, in my opinion, is some type of closed top feeder. There are all types out there. The idea is to put the syrup, a heavy syrup, right on top of the cluster so they can take it right into the hive and store it with a minimum of travel distance.

I have seen four gallon buckets with a very fine mesh hardware cloth over a one inch round hole used often. Placing an empty, full depth super with a lid around this pail you have a perfect feeder. If you don't have such a program, you could use quart to gallon jars

with six very small nail holes in the lid. Use a nail about the size of a frame nail and just put the tip into the lid.

Usually if you have to feed a hive, you need to feed three-four gallons of heavy syrup. That means about 20 lbs. of sugar per four gallons of water, or more if you can. The idea is to get the maximum number of gallons of heavy syrup into the bees as fast as possible. Then go back and heft.

FEEDING TIME OF YEAR Ideally you should feed when it is warm and the bees are flying so they can properly cure the syrup. It is simply better for the bees for wintering and for ease of curing the syrup. If they need feed and it is



Top feeder. Bees have access from below to syrup in chambers, holds lots of syrup, you don't have to open colony to feed, but they are expensive, and not used for much else.

already December, well, it is called "catch up beekeeping," but do feed them. I recall one year I was feeding bees in the morning and attended our yearly beekeepers' meeting that afternoon. It was December seventh. The bees made it, though it would have been better to feed earlier, but that year it did not happen on time.

INSIDE FEEDERS Inside feeders are quite good. They replace one frame and are usually made of a hard, molded plastic. Sometimes you'll see old wooden models, but not much anymore. I have seen one place they are made and I suggested they rough up the inside surface because when they are new, they become death traps. A few years later they did start grinding the inner surface, but it really did not make a big difference. Inside feeders need one piece of hardware cloth cut to the length and height of the feeder so the bees can get out.

These feeders work wonderfully in

the warmth of the fall and the bees will empty the one gallon contents in about two days. Then feed them again and again until they heft right, which means three - four gallons.

AMOUNT OF FEED I do not know why it is, but a hive that has to be fed syrup eats more sugar in weight than the same hive next door eating honey. The three - four gallons of syrup, had it been honey sealed and stored in the comb would be plenty for the winter. But my experience with bees on the take is that the first three - four gallons gets them through the winter, but you must feed them in March to get them to the first honey flow. They are always rattling dry by the end of February

SPRING FEEDING Unfortunately, fall feeding is usually followed by spring feeding. This is another topic altogether, as there are different factors that affect how you feed the bees and how much you feed them. Look for that article closer to next Spring.

I wish you all could come with me to feed 1,000 hives in the fall of the year, knowing any day there are snow storms on the way and you have only been able to get two gallons of syrup into the hives. Or how about spending Thanksgiving day feeding 200 hives, knowing every time you feed one gallon of syrup you just said good by to \$3.50 worth of profits.

Well, the ache in your back and the drain on your bank account is a mighty hard teacher. But if you are sharp you learn from your mistakes, and if you're like me, you usually learn it the **HARD WAY**. But you'll also learn how *not* to have to feed your bees next year. ◊

For a Special Christmas
We're Giving 10% Off On All
Candle Molds

B.J. Sherriff's
the Honey Rustler
\$88.00 S,M,L
\$96.80 XL & XXL



**BRUSHY MOUNTAIN
BEE FARM INC.**

Rt. 1 Box 135
Moravian Falls, NC 28654
Call For Free Catalog
1-800 BEESWAX

MISSISSIPPI

S · P · L · I · T

KIM FLOTTUM

For two incredible weeks each October nearly 11,000 two-story colonies, moved from thousands of yards in North Dakota, South Dakota and Minnesota are trucked to winter quarters in the very southern part of southern Mississippi. The event is without question high drama, fine art, and produces a unique set of risks known only to beekeepers. It is also very, very good business.

These colonies all belong to Adee Honey Farms, Inc., whose heart and soul reside in the tiny town (pop. 350) of Bruce, South Dakota. But this business has a reach that includes, at the peak of the season, over 40,000 colonies, comfortably covers the best parts of Kansas, Nebraska, South Dakota, North Dakota, Minnesota and Mississippi, employs 35 full time employees (with an \$800,000/year payroll), and produces, during even an average year, enough honey to float a small ocean liner.

In this and two following articles we will examine how Adee Honey Farms manages the basic biology of honey bee honey production to its greatest degree and greatest advantage. We start this month in southern Mississippi, near Woodville, in the very southwest corner of the state. Here we'll look at how they use the honey bee's natural drive to reproduce (swarm) to their advantage by producing, on average, four and a quarter splits from every one of those two-story colonies they just moved there.

Next month we'll head north and watch how, by taking advantage of the honey bee's 'hoarding instinct' these beekeepers are able to harvest bumper crops (by most standards, anyway) every year.

And finally we'll finish in December with a casual but candid conversation with Richard Adee, a first rate, second generation beekeeper who knows his business, and what it takes to stay

Adee's also run about 13,000 colonies in Nebraska and Kansas, and each year 3 - 4,000 of the weakest and oldest are replaced with strong honey producers moved down from the northern operation. They are wintered there, wrapped in black corrugated plastic, two to a stand. They will be ready to go next spring.

An arrangement made several seasons ago with Horace Bell, a large commercial operator in Deland, Florida takes care of another 10-15,000 good colonies left in the north. Adee's crews push four deeps' worth of bees into a single deep, which are then shipped to Florida on Bell's trucks. Horace uses them to stock his own nucs in preparation for his colonies needed for migration and honey production the following spring. He

installs the bees in his boxes then ships the Adee's equipment back to Mississippi, to be used there in making nucs. He also sends back some honey in this deal.

One or two loads of good colonies are kept in the Bruce, South Dakota staging area as a backup, just in case a load is lost in transit (accidents happen), more colonies are needed in Kansas or Nebraska, or a Florida truck doesn't make it.

When the 10,000 plus two-story colonies reach the Woodville, Mississippi staging area in mid-October, they are taken to their 'winter' locations to begin building for the spring ahead. Adee's have about 170-175 locations,

Adee Honey Farms, Inc. covers the best parts of South Dakota, North Dakota, Minnesota, Kansas, Nebraska and even Mississippi.

in business. No matter what.

But now, let's head down to Woodville, Mississippi, and watch how Adee Honey Farms performs the annual Mississippi Split.

In late July crews evaluate every colony in every yard as they go through harvesting honey. Each colony is placed into one of several categories - roughly: Keep and send to Mississippi; keep and overwinter in Nebraska and Kansas; keep and sell bees to a Florida beekeeper (read more of this later); keep, just in case; don't keep.

This year the Adee's are shipping 24 trailer loads of bees to their facility in Mississippi. The colonies are two-deep, with 432 colonies on each load. If you don't have a calculator handy that's 10,368 two-story colonies shipped south.

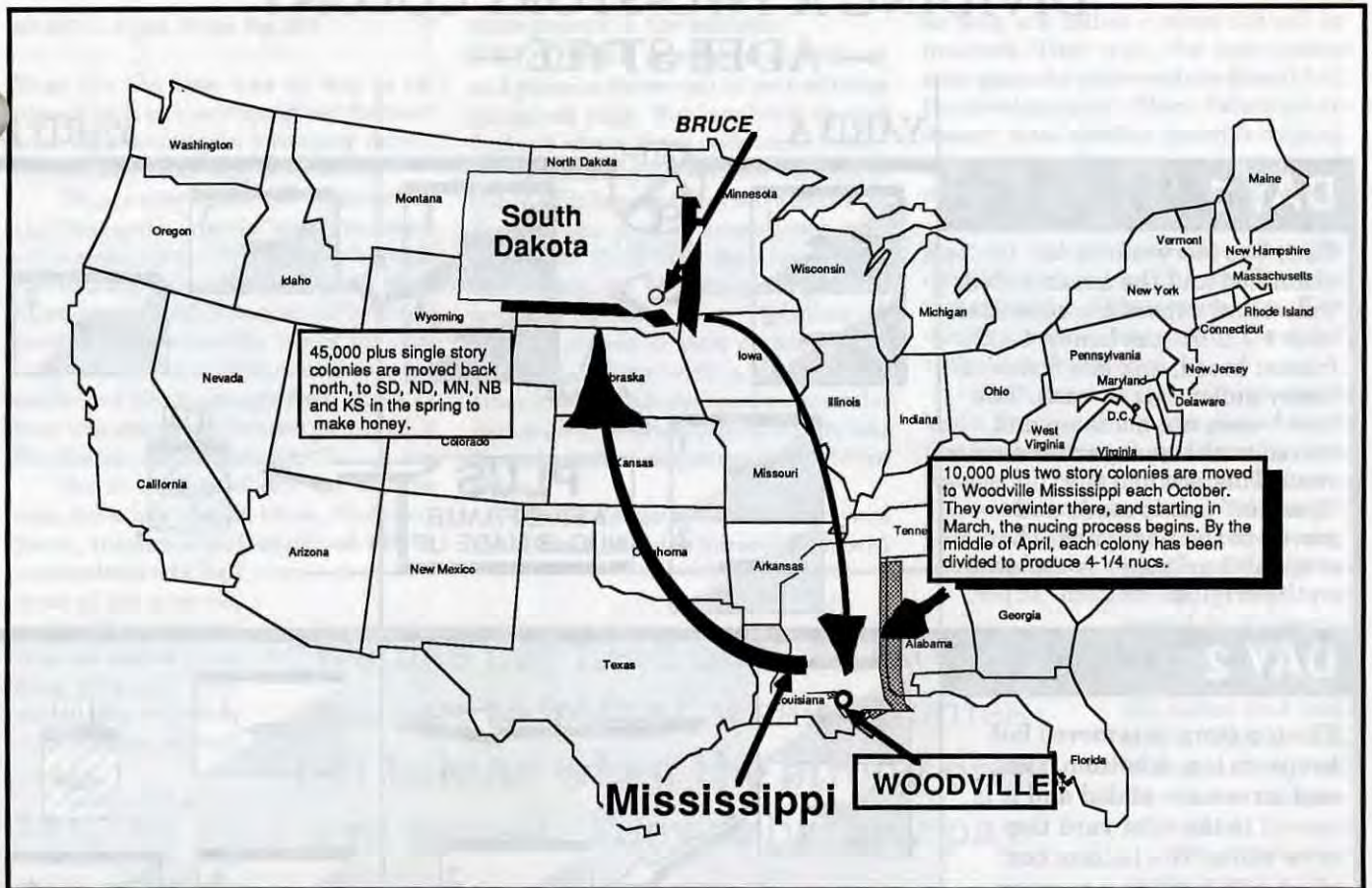

mostly pasture areas surrounded by timber, and put 60 colonies per location.

Then, things slow down a bit. The bees build strong on the ample forage and the crew takes a breather until after the first of the year – when the real fun begins.

By late February the Mississippi crew has already moved down and set up housekeeping in the huge company house in Woodville. The six bedroom home easily handles 14 people, along with a three person trailer by the house and another place in the country. A large crew is needed for the next several weeks.

The first chore is to begin making up the equipment needed for the splits. Eight to ten people assemble these by taking an empty deep, stapling on the bottom, adding a cleat and screen in front, and putting in nine frames. The diagram shows how the frames are assembled. The crews prefer to add two half-frames of honey, (or one full frame), because a half frame puts less stress on the top bar and two are easier to eventually distribute in the box.

They make up 9,000 nucs/week, and it takes four weeks and two days (give or take a day) to put together the 38,000 nucs needed. They also make up several hundred five-frame nucs – one of which goes to each yard to replace any 'blow-outs' that happen in the yard.

The Mississippi Split

Making splits is basically taking advantage of the honey bee's natural

DAY ONE each three man nucing crew goes out to examine the now-buster two-story colonies in three yards. The examination process goes something like this Each colony is opened and inspected. The queen is found (85% of the time, anyway) and killed. Then, two of the prepared nuc boxes brought along are set next to the colony for the next step.

The crew goes through each two-story colony and, using the available

This process won't work for everybody, but the principles are straight forward and easy to adjust.

instinct to reproduce. Here's how it works in Mississippi, when the weather works and the equipment works and everything goes like it goes almost every year.

The Adee's divide their nucing process into two distinct phases, spread over two days, and involving two different apiaries for each colony that gets divided.

brood, bees, honey and pollen sets up four identical boxes. Each finished box gets one and a half frames of honey, one and a half frames of brood and one frame of pollen. Each box has a screen and cleat attached to keep traffic to a minimum.

The two 'new' nucs are loaded on the truck to be moved to the next yard the crew visits, about three miles away.

DIVIDING A TWO-STORY COLONY — ADEE STYLE —

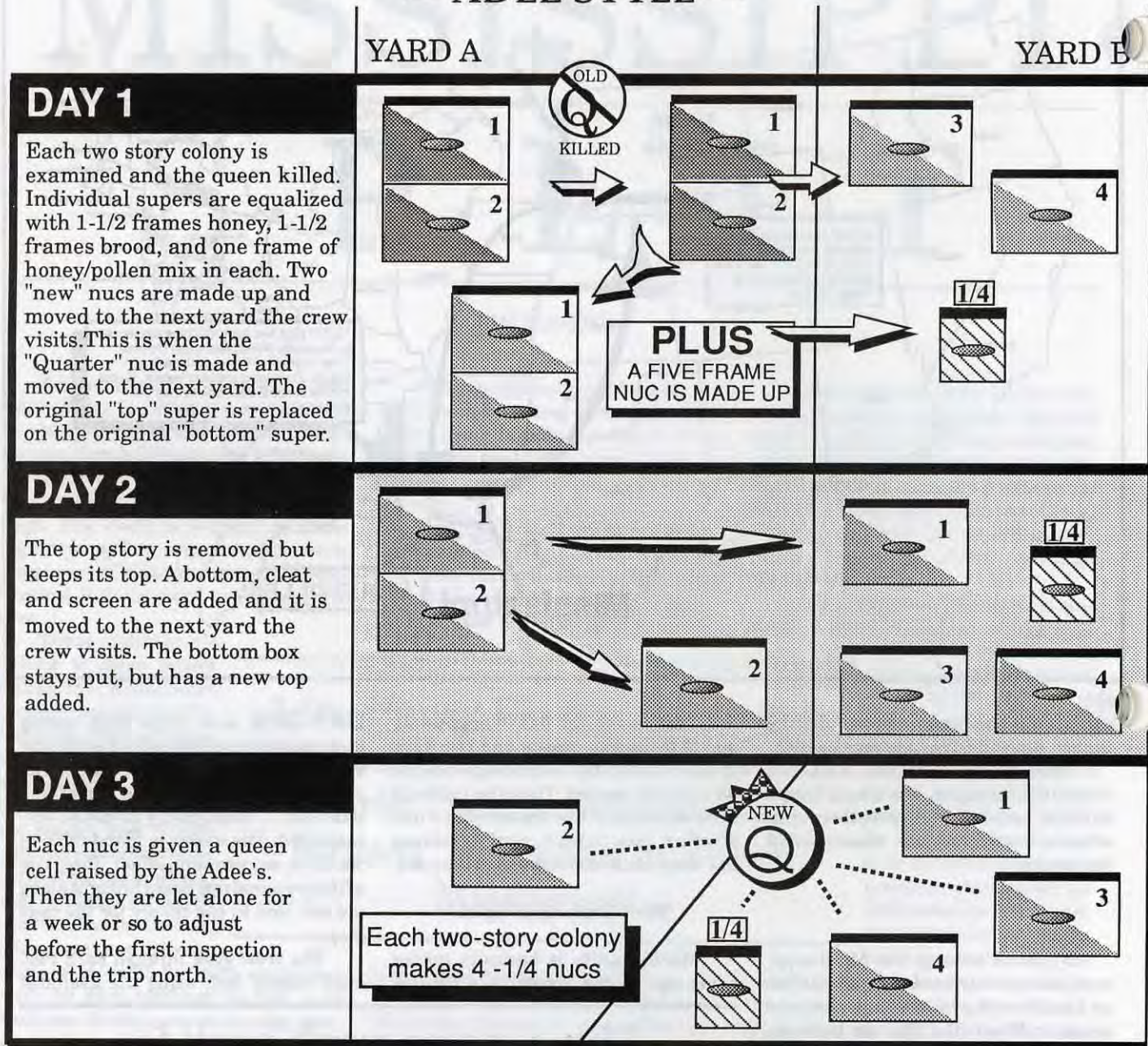

MAKE-UP OF AN ADEE NUC

A typical nuc is made up of nine frames that usually total 1-1/2 frames of honey, 1-1/2 frames of brood and one pollen. However, they don't always fall that way. Rather, they are more often like the one next door. Frames 1 & 2 are empty drawn comb. Three is a pollen/honey mix, 4 is mostly honey, 5 is mostly brood with some honey, 6 is the same, 7 is mostly honey and 8 & 9 are empty. But the final mix usually falls within the range they expect.

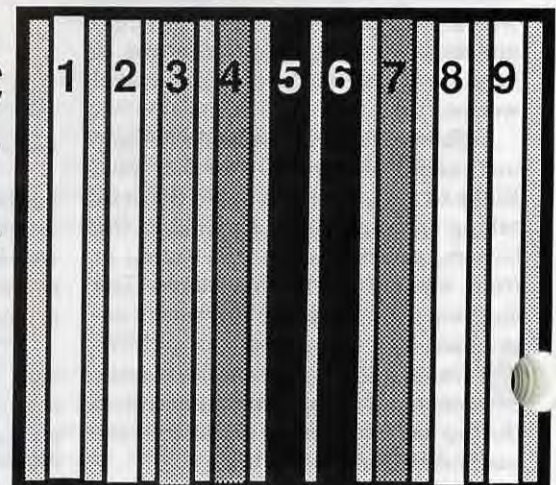

Then the box that was on 'top' is replaced, so it sits on its original 'bottom' box. This once-again two-story colony collects any returning field bees.

This is also where the "quarter", of the "four and a quarter" nucs/two-story colony comes from. While going through the two-story colonies, some will have more bees, brood, honey or pollen than needed to comfortably make up four even boxes. These extra frames are set aside and when enough from three or four two-story colonies are gathered, a five frame nuc is made up.

So, at the end of day one a three man crew has visited three, 60-colony yards, inspected and equalized 180 or so colonies (and killed most of the queens), split off two 'nucs' that are moved to the next yard, and reinstated the two-story colony on its original stand.

Let's call it a day.
DAY TWO The 'splitting in the middle crew' goes to work. An ambitious bunch, early in the a.m. they load their

truck with . . . tops and bottoms. Then they set out to rid themselves of even these.

This crew moves into a yard, removing the top box on the two-story colony left from yesterday, keeping the lid it already has, and putting it on a bottom board. Then they put a top on the bottom box left in its original spot.

A trick they use is to stack those top stories, complete with tops and bottoms, six high at intervals in the yard. Then, using an electric staple gun they fasten box and bottom together, add cleats and screens to make an easy-to-move colony.

Stacked six high, workers can go through a 60 colony site in a hurry, and labor is kept to a minimum. These top boxes are then moved to the next yard the crew visits.

To review . . . on day two an already-examined two-story colony is divided into two 'splits', with the top story moved to another yard, while the 'bottom' stays on the original site. So, by the time the sun sets, each yard that was worked that day has 255 queenless colonies (nucs) instead of the 60 that were there in the morning. This is swarm

management in the extreme.

DAY THREE Another crew sets out and places a queen cell in each of these queenless nucs. But lets back up and find out where these cells come from.

Adee Honey Farms raises their own queen cells because they have control of the process, and it keeps costs to a minimum. They raise Starline queens, exclusively, by obtaining 15 grafting mothers directly from Hybribee in Florida. Adee's is part owner of this operation, along with a dozen or so other queen producers and commercial beekeepers. A royalty is paid to Hybribee for each production queen produced from these.

Richard Adee runs the queen yard the cells are raised in himself. He has 15

"We use our field bees as often as we can to 'refuel' weak colonies left behind when the strong ones are moved. They definitely pay their way."

mother colonies, and picks grafting frames from the eight - ten best. In this yard are also 22 'starter' colonies (sometimes called cell builders) and 110 finishers - nearly 150 colonies all together.

Richard and sons Bret and Kelvin do the grafting. Their schedule is such that they can harvest 1800 cells/day during a five day work week.

They set up the queen yard in plenty of time to build strong populations in the cell builders and finishers. Lots and lots of young bees are necessary.

Grafting begins in late February. The timing allows for the three days before an egg hatches, grafting 24 hour old or less larva, the five and a half days from larva to capped cell, and three to five days of pupation. Altogether, grafting must begin 11-13 days before the cell is needed in the finished nuc.

The first graft comes off (cells harvested) on the fifth or sixth of March, three days after the nucing process begins. Because of this there is a two to three day grace period to allow for bad weather slowing the process. Adee's want the nucs to have been queenless long enough that they have just begun building queen cells of their own - "buds"

as they are called - when the cell is inserted. That way, the new queen emerges so far advanced she doesn't kill the developing cell. Then, if she's lost or doesn't mate another queen is waiting in the wings. This process has assured a 94% acceptance rate over the years.

To install cells a two-man crew goes out two to three days after the colonies were originally split. They can install 900-1,000 queens/day. The nucing process is complete by the end of the first week in April.

The third week in April inspections begin. By now every nuc *should* have five frames of brood, and seven to nine frames full of brood, bees and stores. The colonies are checked, and the strongest from each yard are moved out,

heading for the trip north. They are moved in the morning because the field bees, those that are the oldest and best able to forage, are left behind, to strengthen the weaker colonies left behind.

Ten days to two weeks later it's time to check again, and again the strongest colonies are taken in

the morning, leaving the field bees to help out the weaker colonies left behind. These inspection crews can check 400-500 colonies/day/person on an "average" day.

This process occurs again, only in less than the 10 day wait when the last of the colonies are moved out. This occurs about the tenth of May.

Meanwhile, the 150 or so colonies from the queen production yard have been split out and let grow up. Because of the high population of bees in these colonies they routinely get five and a half nucs/colony - or 800 nucs to move north.

Basically, that's the Mississippi Split. The same process won't work for everybody, but the principles are straight forward and easy to adjust. The Cardinal rule, if you wish, is that if you work *with* the bees you will succeed. Work against them and you will not.

Next month we'll follow Adee's bees from the time they arrive up north until it's time to move south again.

Stay tuned. ☺

B · E · E B · E · E

T · R · E · E

B.A. STRINGER

The Bee Bee tree, *Evodia daniellii*, became an overnight sensation to beekeepers after it was introduced in the *American Bee Journal* and *Gleanings in Bee Culture* magazines in late 1955. Mr. Fred W. Schwoebel, Curator of the Langstroth Bee Garden at the Morris Arboretum in Philadelphia, wrote; "Once in a great while a potentially important plant is introduced into a new environment and it is many years before its value is appreciated. Beekeepers may have such a hitherto unrecognized plant in the Bee Bee tree, or Chinese Evodia."

The Bee Bee Tree was introduced into the United States in 1905 and was still rare in 1955. Most specimens were planted in botanical gar-

dens or on the grounds of a few collectors. Mr. Schwoebel observed the tree at the Morris Arboretum over a few years and emphasized that his observations were not any indication of the quality or quantity of the honey produced.

He said the long-flowering trees were worked intensively by honey bees during the dearth of other floral nectar from mid July through August and the tree bloomed prolifically, providing an abundant source of nectar. "Flowers are small, waxy white, and are borne in clusters . . . often worked by 20 or more excited bees on a single cluster."

Of particular note was the fast growth from seed to first bloom, a period of about eight years, and the ability of the tree to reseed itself. Mr. Schwoebel wrote that "No special skill is required

for its propagation. A shallow super was placed on the ground enclosing a few spadefuls of newly turned earth in November, 1954, and about 100 seeds were scratched into the surface. With no further care, germination this spring was better than 50%."

The hardiness of the Bee Bee Tree was also of interest to many. Trees had been growing well at the Arnold Arboretum in Boston for many years, and there were hopes that the tree would

female tree bears seeds. I grew several seedlings from their stock for three years, until severe winter weather killed them. Perhaps the trees would not survive in areas colder than this, USDA Zone 8, without winter protection.

In the early 1960's, Mr. Alex Summers of New York planted a variety of trees and shrubs to attract birds. Many of these species were also excellent bee plants. He keyed out three different species of *Evodia* to be, in reality, all

Evodia hupehensis. This particular species of Bee Bee tree was discovered by Ernest Wilson while he was collecting for the Harvard University's Arnold Arboretum in the Chinese provinces of Shensi and Hupeh. The species was introduced to

the United States in 1908.

Mr. Summers described his trees as having green twigs, branching pyramidal flower clusters and reddish beaked fruits. He wrote that trees bore separate male and female flowers, but that both might be found in the same flower cluster. He differentiated his plants from *Evodia daniellii*, which has reddish twigs, flat corymbs of flower clusters 12" across and purple beaked fruit. Apparently the two closely allied species were frequently confused in the nursery trade, but all were attractive to bees.

After 15 years of growth, some of the trees which had not bloomed at all were culled, according to Mr. Summers. The *E. hupehensis* that did flower were "covered by a cloud of bees" The leaves dropped very late in the fall and the

This Tree Is Good For Homeowners, Bird Lovers and Beekeepers

become a permanent part of the national flora.

The tree grows to about 40 feet in an open area and is an attractive addition to lawn or shade tree plantings. In four years, a seedling at the Morris Arboretum had reached 18' in height. The seed-bearing female tree turns a deep wine-red color as the seed pods ripen. Many species of birds are attracted to the October-ripening seeds, and the tree could provide valuable forage along migration routes. Small game, quail, grouse and doves could also benefit from the fallen seeds.

The Langstroth Bee Garden for a time offered seeds to beekeepers and other people interested in propagating Bee Bee trees. The Arboretum suggested planting several trees within a limited area if seed was desired, as only the

small black seeds were seen to be eaten by Vireos, Doves, Mockingbirds, Grosbeaks, Warblers and other birds.

Older *Evodia* trees grew trunks as large as four feet in diameter with very smooth grey bark. The mature trees have a rounded canopy similar to maples, and heavy branches. Some suckering may occur, and seedlings self-sow prolifically in sun or part shade.

The name *Evodia* is derived from the Greek word *euodia*, meaning sweet scent (the leaves are aromatic). In references, the botanical name is variously listed as *Euodia* or *Evodia*. The tree is in the Rutaceae family, along with such familiar plants as *Citrus*,

Skimmia, *Rue* and *Dictamnus* (Gas Plant).

Mr. Summers concluded that "Evodias are ideal horticultural, avicultural and apicultural subjects. A joy and a delight at all seasons."

Mr. Schwoebel believed that "more can be done to restore our lost bee pasturage by the planting of suitable nectar-yielding trees than by any other method. . . It is the plants that produce the honey and without suitable nectar-bearing plants the bees are helpless."

Little feedback has been forthcoming about the Bee Bee tree in recent years, despite the numerous seeds and seedlings which were distributed among

beekeepers in 1955. Mr. Luis Culp, the current Curator of the Langstroth Bee Garden, has 30-50 mature *Evodia* trees available to his bees and cautions that he has "not seen a surplus of nectar it is my belief that the *Evodia* provides maintenance nectar only, which is very important during the time of bloom."

If you are interested in trying the Bee Bee tree in your area, please send your request for seeds with a stamped self-addressed envelope and a donation to the Langstroth Bee Garden to: Luis Culp, Curator of the Langstroth Bee Garden, Morris Arboretum, 9414 Meadowbrook Ave., Philadelphia, PA 19118. ☐



Gift Boxes
for Honey or Candles

Call Us Today to order your boxes

Call us:
1-800-547-1392
or Fax us:
(913) 492-2742

MID CON
Agrimarketing

8833 Quivira Road
Overland Park, KS
66215-3913



NEED QUEENS?

CALL DIAL-A-QUEEN
1-800-333-7677

QUEEN PRICES • AFTER MAY 15TH

1-12	\$6.00
13-39	5.00
40-99	4.50
100-up	4.00

"THEY PRODUCE"

Rossman
Apiaries
INCORPORATED

WRITE, CALL OR FAX FOR FREE CATALOG

P.O. Box 905
Moultrie, GA 31776 • (912) 985-7200 • FAX (912) 985-0209







COLONY QUILT™

COLONY QUILT™ is made from a patented combination of foam and polyethylene which provides a thermal blanket for better wintering.

THE BEST WINTER PACKAGING AVAILABLE

- **INDESTRUCTIBLE**
Can't break, crack or deteriorate from exposure to sun, snow, ice or water.
- **EASY TO INSTALL**
Reduce labor to wrap a colony or group of colonies to a matter of seconds.
- **LIGHTWEIGHT**
225 foot roll weighs only a few pounds and is easy to store and transport.
- **FLEXIBLE**
Easy to adapt to any size or type of equipment standard or not with no special preparations or loss in effectiveness.
- **HI-R VALUE — 6.2** (More than 3-1/2" of glass insulation)
Not just a windbreak, actually holds heat in resulting in looser clusters and better overwintering.
- **INEXPENSIVE**
Wrap your colonies for as little as \$1.25/colony and use for years and years.

ALSO
FROM
B & B

QUALITY EQUIPMENT & SUPPLIES AT LOW PRICES
ALL TYPES OF HONEY CONTAINERS & GIFT ITEMS
CANDLE MOLDS & SUPPLIES & CRAFTWAX
EXPERT ADVICE AND FAST PERSONAL SERVICE

Available only from

B & B HONEY FARM

Rt. 2 - Box 245 • Houston, MN 55943 • (507) 896-3955

FREE CATALOG

MEET JOHN MILLER

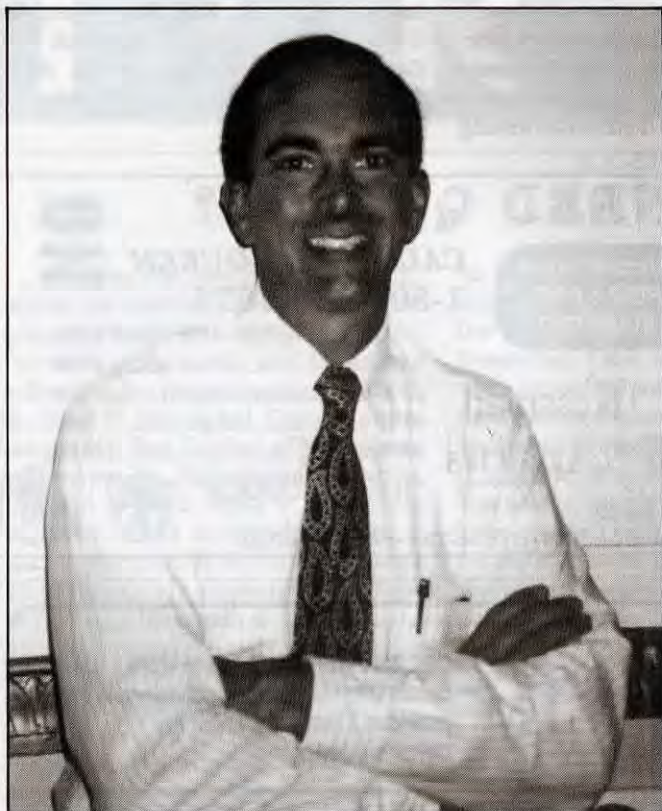

“I have a commitment to my livelihood. I expect to make a profit. If I don’t I’m out of business.”

The newest director from Region Three on the National Honey Board runs 8,000 colonies, migrates between California and North Dakota, pollinates almonds and is in the fourth generation of a family beekeeping business that started in 1894.

This newest director belongs to the American Honey Producers, the American Beekeeping Federation, the Mid U.S. Honey Producers, both the California and North Dakota State Beekeeping Associations and the CalDak Migrating Beekeepers. Whew!

He’s also one of the more informative (and outspoken) honey price reporters, in two regions no less, for the monthly honey price report appearing on these pages each month.

Add to this his just-completed two-term experience as a board alternate, the fact that both his dad and an aunt are on the board, too, and you’d probably think you’d found a pretty good candidate. There’s more.

But first, let me introduce John Miller, and tell you a bit about his operation.

Starting in January, John and his crew start moving his 6,000 double deeps from the North Dakota/Idaho region where they have been since last spring, making honey all summer and surviving the cold ‘till the move. He and his crew use all or most of the nine trucks he owns (he leases the tractors), and by February first has all 6,000 in the almonds.

“I supply strong colonies, in the right place and on time”, he says. “Worry free service”, for the growers I contract with.

The bees sit in the almonds until about mid-March, when they move north to the mountain area in Placer County. There, they are split, requeened, equalized and inspected. The 11,000 nucs made consist of three frames of brood, honey and pollen in a 10-frame box. This is finished by April 22, when the decision of where to move is made.

“We look at the dandelion crop in Idaho and Montana and the willow in Wyoming to see which is best for build-up. We’ll stay in any or all of these until about June first. The stronger hives are moved home to North Dakota as soon as the weather settles there”, he said, “and the weaker colonies are left for last, to build as long as possible.”

When the colonies are set they are inspected again for stores, overall health and queenlessness. Everything must be primed and ready to go when the honey flow hits.

Given enough rain, and some warm weather, the clover and alfalfa around Miller’s Gackle, North Dakota home can

easily produce a 100 lb. average.

Honey supers are all 6-5/8" size, and they get added just before needed (almost always, anyway), by the 11 man crew that works summers in Gackle.

Consistency and good timing are paramount for success and guessing just doesn't work. A detailed knowledge of the area is important, certainly, but good records are even more important.

"We keep all our records manually. Each crew takes notes when they visit a yard. Each manipulation is recorded (supering, medication, harvesting) on a yard sheet with room for 24 entries each season," John said. "It's true you know, good records make good beekeepers," he added.

This same crew also removes supers starting mid-summer for extraction. Miller runs a Guinness uncapper, but uses a home-made extractor that holds 12 supers at a time.

"We can do about seven barrels an hour, (that's nearly two ton), but then the real work starts," said Miller.

"I have a commitment to my livelihood" he said, "and I expect to make a profit. If I don't, I'm out of business, and the nearly 20 people who work for me (both full and part time) are out of work.

"My target market is the honey packer because I'm a honey producer", Miller said. "I need to cultivate that mar-

ket, that packer, to make myself valuable. I *must* provide better service than *any* off-shore supplier, provide a better product, be more reliable – I can't compete with price, so I've got to give more – provide a 'value-added' product. That is my advantage, and that is what keeps me in business," he said.

"Packers are not adversaries, they are only one link in the chain between honey bee, and honey on the table. Some day there won't be a government program as a buffer," Miller summed up.

And that pretty well sums up the attributes of the newest producer member of the National Honey Board. A honey producer, who works well with his best customer, while supporting the rights and needs of his employees and pollination contracts.

Oh, and the last item regarding Miller?

Back in 1958, John's grandfather, Woodrow, teamed up with Ralph Gamber of Dutch Gold Honey, in Lancaster, PA to develop the original squeezable honey bear. ◻

Portions of this article were taken from the Dutch Gold newsletter "Honey", written by Jill Clark, Editor.

COWEN MANUFACTURING COMPANY

P.O. Box 399 • Parowan, Utah 84761-0399
Telephone (801) 477 8902 (801) 477-3338
FAX (801) 477-3569

"BRUSH UNCAPPER"

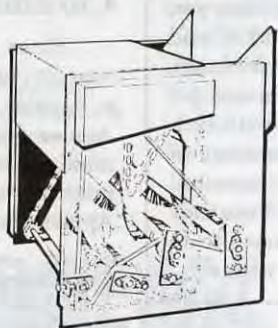

Please Be Patient With Us

Engineering problems have kept us from going into production on the "BRUSH UNCAPPER" We are certain we will have these problems worked out, the new "BRUSH UNCAPPER" will be available soon.

Name _____
Address _____
City _____ State _____ Zip _____

BETTERBEE INC.

CLEAR BEARS

Our 12 oz. clear bears are now more squeezable. Available with red, yellow or gold tamper proof flip tops and yellow collar labels.

Case of 250 – October Special
\$59.95 & 25 lbs. shipping.

Discount Pricing on Maxant
Extracting Equipment.

BETTERBEE INC.

R.R. #4, Box 4070

Greenwich, NY 12834 USA

Phone and Fax # (518) 692-9669

Write for free discount Beekeeping catalogue.

Include U.P.S. shipping charges with all orders.

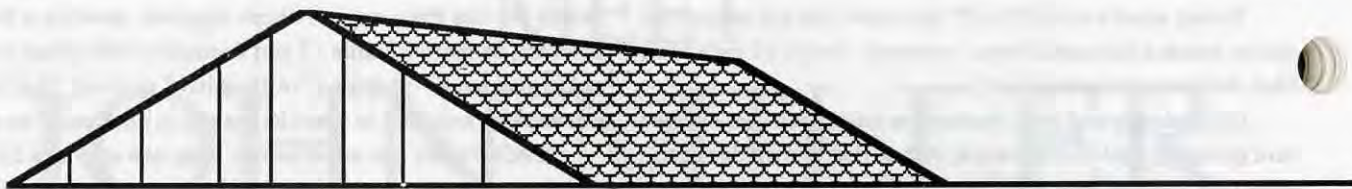

HOME HARMONY

ANN HARMAN
6511 Griffith Road • Laytonsville, MD 20882

HURRAY FOR HALLOWEEN!

It's Halloween!

Wait – before you say “That’s for kids” and turn the page, think for a minute how much fun Halloween can be for everyone, young or old. True, children have school parties and go out for “Trick or Treats”, all while they’re dressed in fanciful costumes. But Halloween is a “Treats” day where candies and cakes take an important place in the day’s festivities, along with witches and goblins. Cakes, cookies and candies are the perfect foods to be made with honey. Honey will contribute the sweet along with a flavor to make the day’s Treats special.

And so this article is for all ages: for the children to make some Treats for their friends and schoolmates, and for the adults to cheer up an ordinary day just before winter weather sets in.

Honey Fudge Cake

First of all a plate of cupcakes makes a nice display and gives an opportunity for colorful icing with decorations. Halloween colors are traditionally orange and black, so we will keep those colors with the cupcakes. Use fluted paper muffin-tin liners for ease in serving.

3 1-oz. squares unsweetened chocolate, melted
1 cup milk
1-1/3 cup honey
3 eggs
1/2 cup shortening
1-1/4 tsp vanilla
2 cups sifted cake flour
1 tsp soda
1 tsp baking powder
1/2 tsp salt

Combine melted chocolate, 1/3 cup of the milk, 1/3 cup of the honey and 1 well-beaten egg in a saucepan. Cook over low

heat, stirring constantly until thickened, then cool. Cream shortening and vanilla. Continue creaming while adding 1 cup honey in a fine stream. Add remaining eggs, one at a time, beating well after each addition. Sift together flour, soda, baking powder and salt. Combine cooled chocolate mixture with 2/3 cup milk. Add dry ingredients to creamed mixture alternately with chocolate mixture, beating well after each addition until smooth. For a cake: Pour into 2 greased, paper-lined 9” round pans. Bake at 350° for 25 to

Colored plastic wrap can be difficult to find but the Halloween Treats may need to be wrapped. Use plain kitchen plastic wrap and tie with the orange or black ribbon you find in gift stores (it’s about 1/4” and curls if run over a dull knife blade). Or take a tip from the kids and get some of the small stickers with Halloween motifs. The assortment of stickers is remarkable and seasonal ones are always available. Since they are “peel and stick” they seem to do very well on most plastic wraps.

30 minutes or until cake tests done. Cool for 5 minutes before removing from pan. For cupcakes: Fill fluted paper cups about 2/3 full. Bake at 325° for 20 to 25 minutes or until done, depending on the size of cupcake.

*Nature’s Golden Treasure
Honey Cookbook*
by Joe M. Parkhill

Easy Orange Frosting

Now for the frosting. You can use your favorite, easy frosting but use some food coloring to make it orange. If you wish to make an orange frosting (the flavors of chocolate and orange are very complimentary) tint it so that it is

a bright Halloween color. Arrange the cupcakes on a large plate and sprinkle candy corn around the edges. Here is an orange frosting that is quick and easy.

1/3 cup butter
1/2 cup honey
1/4 cup frozen orange juice concentrate, unsweetened
1 cup dry milk powder

Mix together. Beat well. Yield: top of 1 cake. Double the recipe for the cake/cupcake recipe above.

The Healthy Taste of Honey
by Larry J.M. Lonik

Caramel Apples

Since Halloween and apple harvest arrive at the same time, apples are a popular Treat, especially Caramel Apples. Children may need a bit of help making this recipe since the caramel mixture requires heating, but Caramel Apples are fun to make!

2 cups honey (dark and flavorful or light and mild – each to taste)
3/4 cup evaporated milk
1 tsp vanilla
1/4 cup butter
dash salt
6 apples
6 popsicle sticks

Combine the honey and milk in a saucepan, stirring constantly until it reaches the firm-ball stage or a candy thermometer reads 255°. Add the remaining ingredients and mix well. Cool to luke-warm. Insert sticks into apple centers and twirl apples in mixture to coat completely (use a tall, narrow container to ensure easy covering). Place on greased cookie sheet or wax paper and let drain. To store, put in fridge.

A Honey Cookbook
A.I. Root Company

Raspberry Honey Cookies

Children think combining a gelatin favorite in a cookie is a great idea!

Treats for children can be made well ahead of Halloween and stored in cookie tins with tight-fitting lids. Then they can be wrapped either individually or several at a time the day before. Honey Treats made by kids for their friends are especially appreciated.

- 1/2 cup butter or margarine
- 2 Tbs raspberry flavored gelatin
- 1/4 cup honey
- 1 tsp vanilla
- 1-1/4 cups flour, sifted
- 1/8 tsp salt
- 1 cup flaked coconut

Cream butter and gelatin. Add honey and vanilla and mix well. Stir in flour, salt and coconut. Chill 30 minutes. Shape into 1" balls. Place on an ungreased baking sheet and press down with fork. Bake at 350° for 10 to 12 minutes. **DO NOT OVERBAKE.**

Ontario Honey Recipe Book
Ontario Beekeepers Association

Peanut Butter Balls

Since this next recipe does not need cooking, young children can make this easily.

- 2 cups peanut butter
- 1 cup wheat germ
- 1 cup dried coconut flakes
- 1/2 tsp ground cloves (optional)
- 2/3 cup honey
- 1 cup chopped dates
- coconut for rolling

Measure all ingredients into a bowl and mix them together with your hands. Roll a tablespoon of the candy mix between the palms of your hands to form a ball, and

then roll in coconut. Store in airtight containers, wrap and freeze, or serve immediately. Makes about 40 candies.

Honey & Spice
By Lorena Laforest Bass

Cream Doodles

Halloween is one holiday that revolves around a great excess of sweets (Thanksgiving has turkey and Easter has eggs). Here is a recipe that contains just lots of good gooey things. Kids love to make them and eat them. I don't blame them a bit—they are fun to make and are really delicious.

- 1 7-oz jar marshmallow creme
- 1 cup peanut butter
- 1/2 cup honey
- 2 1.5-oz chocolate bars, crumbled
- 1-1/2 cups raisins
- 1 cup pecans, chopped
- 2 cups coconut, shredded

Combine marshmallow creme, peanut butter and honey by mixing with an electric mixer until well blended. Add chocolate, raisins and nuts. Mix well. Shape round teaspoonfuls of mixture into 1" balls. Roll in coconut. Chill. Yield 25 balls.

Honey Recipes
North Carolina State Beekeepers Association

Now for a bit of decoration. Spray a couple of sheets of newspaper with black spray paint. When dry, roll one piece into a cone. Cut the other piece to form a brim. Staple or tape the brim on the cone and have wonderful witch's hat. Put the hat on the handle of your kitchen broom and sit this by your front door. Now you are ready for Halloween.



This label is the largest selling commercially available honey label we sell. Some beekeepers have been using it on their Family's Honey for over 100 years. Betty is a *very* popular lady.

But we have all sorts of honey labels you can use. We have them in easy-to-use packs of 100 you can stamp your Business' name and address on, or any other message — like "Merry Christmas" or "Thanks For Being A Good Neighbor"

Or, we can print them for you, with all the information you want, already cut and ready to apply (they come pre-gummed, so all you have to do is moisten and apply).

The label you put *on* your jar is almost as important as the honey you put *in* your jar. Be professional, and be proud of your work. Use Root Honey Labels on your honey jars this year. For more information check your Root Supply Catalog, or call and we'll send you one ASAP

NOSEMA "The Quiet Killer"

Colonies fed FUMIDIL®-B can produce 20% MORE BROOD and 58% MORE HONEY!

You can treat package bees with FUMIDIL®-B for as little as 60 cents!

We also carry:

Terra-Brood™ Mix,
Terramycin[®]
Products, Apistan,
Candle Supplies,
Gift Boxes!



MID-CON

8833 QUIVIRA ROAD
OVERLAND PARK, KS. 66215
(913) 492-1670
(800) 547-1392
FAX (913) 492-2742

MAKING

by DICK BONNEY

O
L
D
E
D



The equipment *Left rear, a one gallon enameled coffee pot for boiling wax. Right rear, a stainless steel pitcher in an old sauce pan makes an adequate double boiler for melting previously cleaned blocks of wax. Center and right foreground, two candle molds. Left foreground, an aluminum fluter for finishing the candle base. The table top is covered with a sheet of galvanized metal.*

C
A
N
D
L
E
S

We live on a tourist route here in western Massachusetts, one traveled by campers, leafpeepers, skiers, many in no great hurry to get somewhere and often looking for a souvenir. We have never considered ourselves a tourist attraction but we do have a "honey for sale" sign out and travelers stop in fair numbers. We've been here for about fifteen years, and at first we were content to sell just honey, although occasionally we thought of offering other things. After all, these people are on vacation, and one of their duties is to spend money. I think what capped it, what really pushed us to look for other products was the day a man looked over our honey display, picked out what he wanted, a one or two pound jar as I remember it, and then turned with a twenty dollar bill in his hand and said, "Don't you have anything else for sale?" We did not, but obviously we should. He seemed disappointed that he could not spend that whole twenty dollars with us. I was, too.

At about the same time I had picked up a candle mold at an EAS conference, and read a couple of articles on candle making. I hadn't actually made any candles, though. The time seemed right — I made some. It was easy. We put a few out for sale and people bought them. A perfect complement for honey sales. They also make great gifts for us to give.

After a while our candles became known in the area and people came looking for them, tourists, some of them on repeat visits, and local residents. At first we had just one mold. It would make six 10" tapers at a time. That's only three pair, though, and one sale could wipe out our whole stock, so I got another mold, and then another, and another — we have about seven molds now, some 10", some 6", and I make 30 to 40 candles at a time.

It just happened that the first mold was an antique reproduction, and all of those purchased since are the same. They make an attractive candle and the antique motif is a good selling point here in rural New England.

As time passed I developed a system of sorts for making the candles. There is nothing unique about my system. It is more a compilation of the tips and techniques I have picked up over the years from articles, from books, and from workshops at EAS. I'll run through it for you.

The Wax

Wax preparation is one of the most important steps. First class candles can be made only from first class wax, that is, cappings wax. When it has been rendered and properly cleaned, it should have a nice yellow color, variously described by some as straw or lemonyellow. The resulting candles will burn slowly, smoothly, and without dripping. The wax should not be tan or brown. The darker waxes contain impurities — propolis and general hive debris primarily — things that can cause the burning candles to spit, to sputter, to burn rapidly, and often to drip.

At first, the wax I used received minimal processing. It was cappings wax, the output of a Kelley cappings melter. The wax that had gone through the cappings melter was remelted in a double boiler arrangement, strained through nylon, and then poured into the candle molds. If I poured carefully, and did not use the wax from the very bottom of the container, all went well. A certain amount of debris would always be present, but it usually settled to the bottom of the double boiler and was not a problem. The color was good, the odor was pleasant — in general they were nice candles. However, the burning time was erratic and frequently the candles sputtered and dripped. This was because of the impurities remaining in the wax — honey, propolis, and whatever else didn't settle out during the melting. Although they were nice looking, I did not consider these to be really first class candles.

Then I came across some information on cleaning wax. It is a simple enough method, although it does violate one of the primary tenets of handling beeswax: never heat wax over direct heat, it is too flammable. To use this method, place a couple of inches of water in a suitable container. Fill the container with pieces of wax, leaving a couple of inches of headroom. Bring the water and wax to a gentle boil and maintain the boil for about fifteen minutes. Watch carefully as the boiling begins. It foams up quickly at the start. In this boiling process, any honey in the wax will be dissolved out. When the container is removed from the heat and allowed to sit for several minutes, the water will settle to the bottom with the dissolved honey. Solid impurities will also settle out, forming a layer between the wax

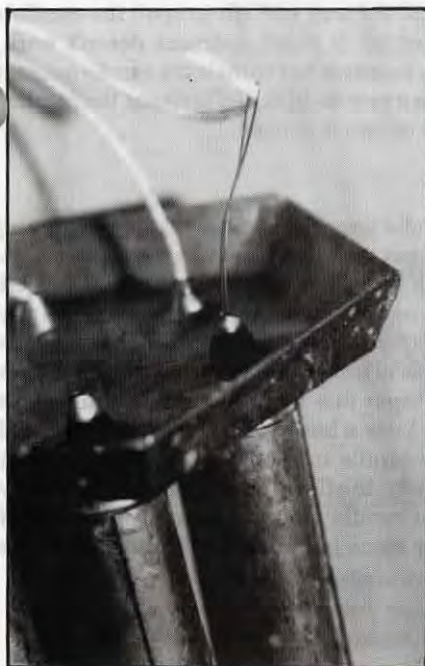

Stringing the wick. The threader and wick can be pulled back through the tip of the mold with a firm tug.



Base of the mold. Each length of wicking is long enough to string through two adjacent candles. They are held taut by mild tension from the bobby pins at the other end of the mold.



Top of the mold. At the top of the mold each wick end is handled independently, held in place by a bobby pin. The large washer (center) raises each pin slightly, away from the base of the candle.



After the pour. The wax has started to set and contract. It will be ready for topping off very soon. Note that there is some wax in the base already.

and the water. The wax, now very clean, will be on top and can be decanted off.

I use a large camp style coffee pot for this operation, and can get eight to ten pounds of clean, usable wax from each run. You can buy or make a melter that will handle more at a time, but I have never felt the need to operate on a larger scale. It is important that whatever container is used, it allows you to pour the wax from the top, leaving the debris undisturbed. After boiling, I let the pot sit off the heat for up to ten minutes, then strain the wax through nylon into waxed milk cartons. The beeswax can be left in the cartons for later use, or it can be poured from them into other molds.

The Mold

My molds are metal, each making either six or eight candles. I have devised a threader, like a needle threader, for handling the wick. It is about 15" long, made from a doubled length of frame wire, fastened to a handle made from a short length of dowel. The threader is pushed into the large end of

the mold, through its length, and out through the small hole at the tip. The wick is slipped into the threader, then it and the wick will come back through the hole together, given a gentle tug.

The wicking is cut long enough so each length will string though two candles. This way it passes out one tip and in the next so that it does not need to be fastened at that end. At the butt end, the wicking is held by bobby pins. These pins make handy little clamps, exerting just enough pressure on the wicking so no knots are necessary.

When pouring the wax, the base (tip end) of the mold is set down on a dampened sponge, the sponge covered by a piece of cloth (to bridge over any holes in the sponge). The cool dampness of the cloth and sponge causes the wax to set immediately at the tip of the candles.

The Pour

Beeswax melts at about 145°F, and expands in the

Continued on Next Page



A pile of candles. One pair does not have the bases fluted. They are the most authentically antique in appearance but they will be more difficult to keep upright in the candlesticks.

MAKING CANDLES ... Cont. From Pg. 571

process. The best temperature for pouring candles seems to be in the range of 180° - 185°F. The wax contracts as it hardens, leaving a substantial depression at the base of the candle (the top of the mold).

Once the wicking has been strung and the mold set down on the sponge, the molten wax can be poured. Allow for the shrinkage: have enough melted wax in reserve to top off each candle after the contraction has occurred. Best results come if the topping off is done before the candle has set completely. You will get a better bond between the candle and the added wax.

Some candle makers pour very carefully so that the resulting candles are precisely the length of the tubes of the mold. I am not this careful. I use the built in tray of the mold and fill it at least half full of wax by the time the pouring is complete. It adds a little work in finishing the candle but I prefer to do the extra and not have to pour precisely.

The Escape

After the candles in the mold have cooled at room temperature for *at least two or three hours*, I put them in the freezer for about an hour. The cold causes the candles to contract a little and they usually will come out of the mold easily. Of course, you must cut the wick at the tip end to free the candles. I usually do this before they go in the freezer.

When you are ready to remove the candles, first remove the bobby pins, then break away that extra wax so that the butt end of each individual candle is exposed. The bobby pins will be partially embedded in the wax, but they usually will break free with little difficulty. Once most of that extra wax is removed, you should be able to pull each individual candle out. The protruding wick-end makes a good handle to pull on.

On those rare occasions when a candle won't come out, don't bang and batter the mold. The molds are tough, but they can easily be deformed. First, try more time in the freezer. If that doesn't work, pour some hot water down the length of the tube in question. Hold the mold so the candle is right side up, and have something underneath to cushion the candle as it drops free. One brief splash of very hot water along the length of the tube is usually enough. Prolonged doses of hot water

can melt the surface of the wax enough to spoil the candle's appearance, so be careful. If this treatment doesn't work, then you may have no recourse but to melt the candle out and start over. Sometimes a new mold doesn't release the candle readily the first time or two it is used.

The Finish

To finish the candle base, I warm the blade of a paring knife and cut the excess wax and wick away. In the beginning, going along with the antique reproduction theme, I left the base trimmed flat across but not tapered or shaped in any way. These looked nice, but our own experience showed us that the candles didn't always stand securely in the candle holder. The candles taper one way, and most candlesticks taper the other. Now I use a base molder to flute the butt of the candle. With the candle in a holder, the fluting is not visible. To work properly, the fluter must be hot. It sits easily on a hot plate. Some candle makers use a box wrench of suitable size to do the same job, fastening it securely to the coil of a hot plate.

The Display

Once we realized that there is a demand for beeswax candles — not great perhaps, but steady — we offered them wholesale to several outlets in addition to selling them from our home. We had to give a little thought to display. Most shops want something more than a random box of loose candles.

Hand dipped candles are relatively easy to display. They are usually left as pairs, joined at the wick end, and hung. However, we're dealing with molded candles and they cannot be left joined or they won't come out of the mold. They must be handled differently. I have tried a couple of kinds of plastic wrapping, both sheets and tubes, and I have tried boxes, the size that holds a single pair. I don't care for either, for reasons of appearance or cost. My solution is to wrap each pair with a simple label and either lay them out in a pile or display them in a small crate. At first I hand printed these labels individually. Now I do them on my computer, printing them out in quantity on sheets. They are 2-3/8" by 4-1/4", black ink on buff paper. The size is governed by the printer paper capacity and could be varied. I also had a card made up to accompany the display of candles. It carries enough information to start people thinking and reminds them that beeswax candles are different.

When we sell our candles at home or at a fair, at the time of sale we wrap each pair in a sheet of tissue paper and put them in a bag. The type of bag used by liquor stores for single bottle sales are a handy size for one or several pairs of candles. Our local liquor store sells them to us for a couple of cents apiece.

Offer More

Candles in a display attract attention. People pick them up, smell them, exclaim over them, and then often move on without buying. We used to set up each year at a Christmas fair. We discovered in many instances that candles offered in conjunction with simple but attractive candle holders sold much more readily than the candles alone. We live in an area that abounds with potters. We were able to buy in modest quantities at a reasonable price pairs of candle holders, allowing us to sell both for under ten dollars, a very acceptable price these days for a gift. ◻

BRANDIES & CORDIALS

FROM

HONEY

PAMELA SPENCE-ALLEN

I am a meadmaker by preference. I mix and measure honey, water, nutrients, acids and tannins. Perhaps I'll experiment with the recipe – add a handful of herbs, hops or the juice of an interesting fruit. Then, like an ancient alchemist, awaken the dormant yeast and set it to work, transforming the mix of elements into the magical brew of mead.

But, of course, the first requirement of a meadmaker is patience. It might be weeks or months before the must begins to clear; many more months (or years!) before the fermentation is complete and the wine has attained proper maturity. In the meantime, you can quell your impatience (and that of friends and family) by blending honey cordials.

You can use relatively inexpensive spirits as a base – honey greatly improves the flavor of even bargain brands. Start cordials in late summer or early fall using fresh ingredients and newly harvested honey. Some of these cordials will be ready to drink within weeks. They will, however, continue to mellow and mature over a period of months.

Historically, American colonists turned to cordials made of honey and ginger for relief from colds and sore throats. Whether or not the cordials provided any direct curative action is open to debate; nevertheless, we can imagine that a warm, honeyed brandy sipped at fireside lifted the spirits of even the most dispirited settler.

PRELIMINARY NOTES

• For mixing and blending, use a large, tightly fitting, screw-top GLASS jar. (DON'T USE PLASTIC). I obtained a good supply of used jars from a local

deli. Wash thoroughly and sterilize with a weak bleach solution (don't forget to do the lid!).

• To filter the cordials, use a funnel lined with a coffee filter.

• Some of these cordials will have a precipitate regardless of filtering. You can either live with it, or let the cordial settle out and siphon the clear liquid off with a turkey baster (buy a new one specifically for this purpose).

• Decorative bottles can be ordered from specialty mail order catalogs (Williams Sonoma or Lillian Vernon, for instance) or re-use small liquor bottles. Use only glass bottles that have previously held foodstuff (beware of bottles from flea markets with suspicious odors or stains).

HONEY HARVEST CORDIAL

1 cup fresh tart fruit (wild blackberries, blueberries, sour cherries, etc.)
3/4 cup light honey
1-1/2 cups vodka

Place all ingredients in a tightly capped bottle and shake vigorously. Let sit in a darkened spot for at least three weeks. Strain liquid off the fruit into decorative bottles. Makes a pleasant cordial, ice-cream topping, or spritzer (mixed with club soda).

HONEY MINT CORDIAL

2 cinnamon sticks
3 whole cloves
1 Tbs raisins
1/8 tsp coarsely ground black pepper
1 qt. brandy
1-1/2 cup honey
1/2 cup fresh mint leaves

Put first five ingredients into a clean dry bottle with a tight fitting lid. Cap the bottle and shake vigorously. Let the mixture steep for 10 days in a darkened spot – shake the bottle every few days.

Prepare the mint honey: In an enamel or stainless steel saucepan, warm the honey gently, holding it just below boiling. As the honey begins to foam, skim and remove from the heat.

Bruise the mint leaves gently and stir into the honey. Cover the mix and let sit for four hours. Heat to just below boiling again, then turn off the heat and let cool. Strain and discard the leaves. Strain the spice-brandy mixture into a clean bottle, add the mint honey, cap and shake well.

Allow the cordial to season another two three weeks then filter into decorative bottles.

ORANGE ELIXIR

2 well scrubbed oranges
32 coffee beans
2 cups 110 proof vodka
2 cups white wine
1/2 - 1 lb. (depending on sweetness desired) honey

Push coffee beans into the skin of the oranges. (Poke the skins with a potato peeler first to make this chore easier.) Place oranges in wide mouthed jar with a tight fitting lid. Add vodka, honey, then wine. Cap tightly and shake vigorously. Let age three-six months, shaking the jar occasionally to help the flavors swap around. Strain into decorative bottles.

LITHUANIAN KRUPNIKAS

1/2 Tbs caraway seeds
5 cloves
5 whole allspice
2 sticks cinnamon
1/2 nutmeg
2 strips orange rind
2 strips lemon rind
1 stick vanilla
2 pieces whole ginger
pinch saffron
1/2 lbs. light honey
1 pint vodka
1 pint water (bottled or spring)

Crack nutmeg and combine with other spices, fruit rind and water in an enamel or stainless steel pan. Bring to a boil and maintain heat until the liquid is reduced to one cup. Strain through clean cheesecloth. Stir in honey and vodka.

Put on LOW heat (do not simmer or boil) until the mix is quite warm, then remove from heat immediately. Cover and let cool to room temperature. Pour into a large, screw top jar and allow to settle for several weeks. Pour (carefully!) or siphon off the sediment and rebottle into decorative bottles. ☺

?Do You Know? Answers

- True** All honeys darken and lose flavor in time. These chemical and physical changes are speeded up by high temperatures. Honey containers should be protected from the sun and high temperatures. These changes can be avoided by storing honey at low temperatures.
- True** Conversion of nectar to honey involves chemical changes brought about by enzymes and physical changes due to the evaporation of some of the water contained in the nectar. Once honey is "ripe", it is sealed in cells with beeswax caps. Normally honey will not be capped until the moisture content is below 19%.
- False** Glucose and fructose are the two main sugars found in honey. The average composition of American honey is fructose (38.2%), glucose (31.3%) and sucrose (1.3%).
- False** Storing honey in a refrigerator is not recommended since the optimum temperature for granulation is 57°F. Granulation is accelerated between 55° and 60° and initiated by fluctuation at 50° to 55°.
- False** During honey granulation, glucose (dextrose) is the sugar that crystallizes out of solution. All other sugars found in honey remain in solution.
- False** The faster honey granulates, the smaller the crystals will be. Slow granulation produces large, coarse crystals.
- True** Honey is hygroscopic: it readily absorbs moisture from moist air and loses it to dry air. Moisture even passes through the wax cappings, so the degree of ripeness at harvest is largely related to the prevailing atmospheric humidity.
- True** During granulation, glucose separates from the liquid phase as crystals, while other sugars remain in solution. As crystallization proceeds the fluid between the crystals increases in water content by about 4-6% producing a favorable medium for fermentation.
- True** Yeasts will not grow below a temperature of 50°F and honey stored below this temperature will not ferment.
- True** Honey may ferment when the moisture content is above 17.1% moisture. As the moisture level increases, the probability of fermentation also increases.
- False** Honey crystallization is a natural process that does not indicate spoilage. It is a super-saturated solution containing more dissolved material than can normally remain in solution and are more or less unstable.
- True** Granulation cannot take place in honey unless there are nuclei present on which the crystals can grow. Bits of dust, pollen grains, and other impurities can serve as nuclei. Filtering honey removes all particulate matter, thus preventing granulation.
- Particulate matter that does not dissolve with heat and was not filtered out remains, the honey was exposed to the air following heating and became recontaminated with yeast cells.
- Osmophilic yeasts occur naturally in nectar, on the bodies of bees, in apiary soil, in honey houses and on honey-extracting equipment.
- Warm honey is easier to extract from combs.
Reliquify crystallized honey.
Kill yeasts in honey.
Filtering or straining of honey.
Reduce moisture levels in honey before extracting it.
Reduces the incorporation of air during the extraction process.
- Honey may not be labeled with the name of a plant or blossom except where the particular plant is the chief floral source of the product.
- The following precautions will minimize the following materials in raw honey.
Moisture - Extract only fully capped combs. Reduce the moisture content of honey before it is extracted by placing supers in an enclosed area with warm, moving, dry air.
Pollen - Keep brood combs out of honey supers.
Wax - Strain honey immediately after extracting.
Air - Warming honey supers prior to extraction will reduce this. Honey should not be allowed to fall very far into a tank. Honey pumps should be located below the supply of honey. To remove air keep honey in a settling tank following extraction and skim the foam off before packing.
- Oval glass jars are preferred because they allow more light to pass through the honey enhancing its appearance.
- Honey from the uncapping and extracting operation usually flows into a sump tank. The tank, normally water jacketed, collects honey so that it can be delivered for further processing at a uniform rate. The sump tank may contain a series of baffles or screens or both for removing coarse wax particles and other foreign material.

Butyric anhydride (Bee-Go™) is a chemical repellent used to drive bees from honey supers as they are being removed from the colony.

There were a possible 25 points in the test this month. Check the table below to determine how well you did. If you scored less than 12 points, do not be discouraged. Keep reading and studying - you will do better in the future.

Number of Points Correct

25-18 Excellent

17-15 Good

14-12 Fair

Candle Making Supplies

Candle Wax • Molds • Scents

WICK

Large Range Of All Candle Making Items

Send For Catalog - \$2.00 Refundable

CANDLEWIC COMPANY

35 Beulah Rd., Dept. A

New Britain, PA 18901

(215) 348-9285

WEAVER'S FAMOUS QUEENS

• ALL-AMERICAN (Italian)

• BUCKFAST

WEAVER APIARIES, INC.

RT. 1, BOX 256

NAVASOTA, TEXAS 77868

Phone: (409) 825-2312

Fax (409) 825-7267

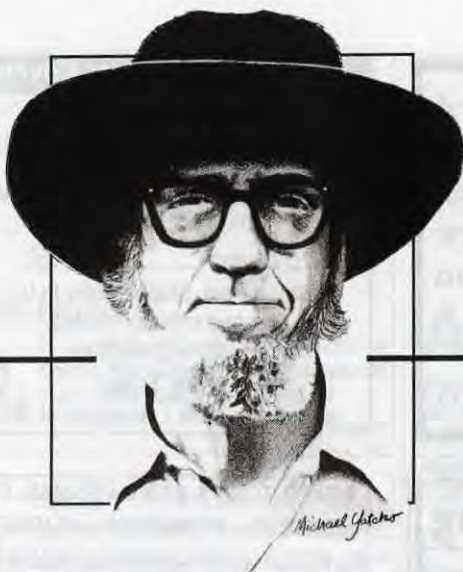

BEE TALK

RICHARD TAYLOR

Box 352, Interlaken, NY 14847

*"Possible solutions
to some real problems."*

I want to talk this time about some of the problems besetting beekeepers these days, but before I do that I want to note how one of my predictions came true. I said last spring that the one thing we could be sure about was that the coming season would be different from any other. That was pretty safe, because I long ago learned that every year is different for a beekeeper. Well, this one certainly was. It rained all the time. The July rainfall broke every record. That's when we usually get our best honey flows here. And now we're more than half way into August and it still hasn't stopped raining. It has been so dark and wet week after week that I've hardly been able to work my solar wax melter. But the surprise is that we've gotten a great honey crop! Mostly basswood. How and when the bees did it I don't know. We know that bees will gather from basswood even in the rain sometimes, but still, I find it incredible.

Now I'll be eager to see what next year's big surprise will be. There is sure to be one.

Okay, now for the problems. I discovered long ago that for every problem, there is a solution. That conviction has worked well for me, not only in beekeeping, but in life. No matter how dark things might seem sometimes, if you just stick it out, think about it, and don't get discouraged, then you will find the solution, and everything will be fine again.

So I have applied this to the problems of beekeeping, and sure enough, the solutions are emerging. Those problems are Tracheal mites, Varroa mites, chalk brood, and Africanized bees. That is quite a bunch of problems, all of recent origin, but don't get discouraged.

They're not nearly as bad as they at first seem.

First, tracheal mites. When these were first discovered on this continent there was much hysteria. For awhile government people were going around killing off colonies, "depopulating" hives, as it was called, in a vain effort to eradicate or restrict the spread of this parasitic mite. That was stupidity born of panic. You cannot eradicate or confine a mite once it has gotten established. So then beekeepers turned to trying to poison them with menthol. Now menthol, though it occurs in nature, is a noxious substance which absolutely should not, in my opinion, be put into a beehive. It only works in warm weather anyway. So it is virtually impossible to use it when there are no supers on the hives. If you wait until you've harvested the honey crop, which is October for most beekeepers, then it will be too late to use menthol, and you certainly cannot use it when the bees are storing honey in supers. This is true in the north. However, those further south will have better luck.

What is the solution? Bees seem already to be developing resistance to these mites. The mites attack only adult bees, and are quite selective of their hosts. Even if we did nothing at all, merely letting nature take her course - which nature has a way of doing anyway - then the tracheal mite problem would eventually be reduced to insignificance, as it seems to have happened in England.

And what do you do meanwhile? Well, these mites are a problem only in causing winter loss. They have no sig-

nificant effect on the bees in the summer. And they rarely if ever cause total winter loss. So suppose you lose even as much as half your colonies some winter. Just get new queens and revive those colonies with combs of brood and bees from the surviving colonies, which resisted the mites, and you are back in business. Your colonies build back up quickly, swarming is much reduced, and you get a fine crop. You also promote resistant strains.

Next, Varroa mites. These are more insidious. They attack the brood as well as the adult bees and once they get into your apiary they will in time kill off every colony unless you do something about them.

Resistant strains are certainly the ultimate solution to this problem. And they already exist. Africanized bees are resistant to Varroa. These bees just chew the mites up and get rid of them. And in Florida, where these mites are everywhere, they are finding resistant colonies. They have found whole large apiaries killed off, with the exception of only one or two colonies which have survived the mites as strong as ever. On closer inspection they have found that these resistant bees, like Africanized bees, just go after the mites and chew them to pieces. These are clearly the bees that are going to survive and spread, so in time the Varroa problem will be solved.

And what can you do meanwhile? If and when you get Varroa in your colonies, use Apistan strips. They kill off the mites, don't hurt the bees, and don't require warm weather. They work by the bees coming in contact with them. You can use them after all the supers are off the hives.

Continued on Next Page

Next, chalkbrood. I've had quite a lot of experience with this. I ignore it. I have never lost a colony to it. When I find chalkbrood pellets in front of a hive, I just figure I won't get much and maybe not any honey from that one this year, and forget it. The bees eventually clear it out. That's how those white pellets end up in front of the hive. And the next year the chalkbrood is gone; maybe its in another hive, but not in that one. It is not very contagious. Sometimes I move a chalkbrood hive out into the open sun, thinking that will help, but I'm not sure it makes much difference.

And finally, Africanized bees. I think there will be problems with these in the south for quite awhile, but I doubt that they will spread to the colder north. If they do, then I'll bet their aggressiveness will have become much moderated in the process. Meanwhile, they have some good points. They are great honey getters, and they resist parasitic mites. So I, at least, will lose no sleep over Africanized bees. Their aggressiveness was born of the harsh conditions for survival in a hot and hostile climate. Nature has a way of adjusting her creatures to conditions, and here, as always, I think nature will have her way in the end. ☐

Comments and questions are welcomed. Enclose stamped envelope for reply, using Interlaken address above.

HOLDER HOMAN & SONS APIARIES

Rt.2, Box 123-B • Shannon, MS 38868
(601) 767-3880 or (601) 767-3855
QUALITY BRED CAUCASIAN & ITALIAN QUEENS



GLOBAL NATURE TOURS, INC.

Presents
Beekeeping tour of New Zealand
2 weeks - Beekeeping - Sightseeing
Jan., 1993 - Guide, Trevor Bryant
Alpha Bees, Te Puke, N.Z.
For details contact:
Global Nature Tours
2701 Oxford Circle
Upper Marlboro, MD 20772
(301) 627-4777



The American Honey Producers Association

All Beekeepers Welcome
Get Involved! Write
P. O. Box 584 • Cheshire, CT 06410

Sugar For Feeding

Granulated sugar. Available in Most U.S. Locations. Please Call:

Bill Heerdegen
St. Simons Trading, Inc.
200 Center on the Lake
Lake St. Louis, MO 63367
(800) 621-9935
(314) 625-2111
FAX: (314) 625-2197



S T O L L E R

FRAME SPACERS



Our spacers are sold from coast to coast. Contact your bee supply dealer for your frame spacer needs.



STOLLER HONEY FARMS INC.
LATTY, OHIO 45855

Specializing In Inner Covers

Thousands in use!
Shipping March 1st - Dec. 1st
5 covers 17.50
10 covers 32.50
15 covers 47.50
Postage Paid. Shipped only in U.S.
Dealers write for quotes.
Orders and Inquiries:
Hive Tops
25123 Co. Rd. 54 Rt. 1 • Nappanee, IN 46550

BOXES-TOPS & BTM'S-FRAMES, ETC. SELECT - COMMERCIAL-BUDGET

For the best value in woodenware, anywhere, call Glenn Miller today. 41% + Freight Discounts.

1-800-827-9266

9-5/8 COM HIVE BODIES 100 (\$4.95)
6-5/8 COM SUPERS 100 (\$3.25)
9-1/8 #1 FRAMES 1,000 (37¢)
COM TOP/BOTTOM 100 (\$3.05)
Minimum Order of \$125.00

Miller Wood Products
2276 Ave. "H" P.O. Box 2414 Dept. "G"
White City, OR 97503

Chrysler's Electric Welded All-Steel Queen Excluder

The only worthwhile Queen Excluder on the market!



- accurate spacing
- allows maximum bee passage
- better ventilation
- more honey production
- no wood / no burr combs
- no sharp edges
- made so durable that it is permanently queen excluding and will last a lifetime. We manufacture a full line of Bee Supplies. Mostly duty-free. Write for prices.

W. A. Chrysler & Son

595 Bloomfield Rd.
Chatham, Ontario, Canada N7M 5J5
Phone: (519) 352-0486



Italian and Carniolan Queens

FALL SALE Effective Sept. 1
1-5 \$8.00
6-24 \$6.75
25-99 \$5.50
100- & up... \$4.75
Mark or clip 50¢



GLENN APIARIES
40521 De Luz Road
Fallbrook CA 92028
Phone/Fax (619) 728-3731

Top Quality, Fertile and Guaranteed to arrive Alive and Healthy
Preventive disease treatment
25 & up via Express Mail
Shipped Postpaid
While supplies last



QUESTIONS?

Fine Finish

Q. If I used all cedar to build a room for super storage would that keep wax moths out?

James Shaw
Ames, IA

A. I doubt it. The scent of cedar repels moths but does not kill them or their larvae. Wax worms are brought inside already in the supers, as eggs and larvae.

Requeen When?

Q. When is the best time to requeen if you want to do it systematically with all your colonies, spring, summer or fall?

Bob Lyons
Pincher Creek, Alberta, Canada

A. Spring, in my opinion, for several reasons: The hives are less populous, so it is easier then; acceptance is better then; you can combine requeening with other apiary work, such as making splits; and you have more time then for yard work, since you are not busy harvesting and extracting.

Varroa Mites

Q. I have nine apiaries, and this year the bee inspector found Varroa in one of them. If I use Apistan strips, must I use two strips in each brood chamber? Should I kill off the colonies this fall? And would the cold weather this winter (20 below zero) kill the mites if there are no bees in the hives to keep them warm?

Donald Wetzel
Beulah, ND

A. Yes, you must use two strips in each colony, according to label instructions. No, do not kill the bees, there would be no point in it. As for your last question, note that parasitic mites cannot survive apart from the bees, whether it is warm or cold. (See "Bee Talk" for this month.)

Candy Comb

Q. Is there any way to degranulate comb honey?

D.M. Durland
St. Regis, MT

A. No, but granulation can be delayed and sometimes prevented altogether by storing in a good freezer.

Fall Feeding

Q. How can you feed sugar syrup to a colony of bees in the fall in such a way that bees from other hives will not take it?

Lewis J. Smith
Clarksville, GA

A. Make only four or five holes in the cover of a one-gallon jar and invert this, filled with syrup, over the inner cover hole. By having only a few holes the bees in the colony the syrup is intended for will get all of it, and it will not be discovered by the bees from neighboring hives.

No Excluder!

Q. Is it okay to leave a queen excluder on a hive all winter?
Marko Watkins
Bourbon, IN

A. Not if there are combs above it, for if the bees move up into those combs then the queen is left below to perish.

Unique?

Q. Do any insects other than honey bees reproduce by parthenogenesis?

John Iannuzzi
Ellicott City, MD

A. Yes, aphids, and most other members of the order *Homoptera* (scale insects, mealy bug, etc.), and termites, among others.

Questions are welcomed. Address Dr. Richard Taylor, Box 352, Interlaken, NY 14847, enclosing stamped envelope for response.

— ANSWERS!

Richard Taylor

GLEANNINGS GLOBE

OCTOBER, 1992

ALL THE NEWS THAT FITS

Sweet All Over? Yuch!

RAISING CANE IN THE SUGAR INDUSTRY

Is the hair-removal world as we know it on the verge of a sugar shock? Don't bet the plantation on it, but one housewife-turned-entrepreneur is convinced she can turn ordinary table sugar into a glamorous beauty treatment. "We expect to take over the waxing industry," says Sandy Alford, whose Alexandria Body Sugaring Inc., based in Canada, now licenses over 10 practitioners in the art of removing body hair with a sugar paste.

Alford says the method has been passed down from ancient times to many Egyptian and Middle Eastern women today. (No, it didn't start out as an embalming technique.) She invested \$10,000 (Canadian) in the venture in 1989 and this year expects more than \$1 million in revenues from training, licensing fees and sales of the glop itself. A press release for the company cheerfully concedes that "razor companies haven't hit the panic but-

ton yet," but adds that "scores of professional cosmeticians, sick of torturing their clients, have moved to sugar" Not everyone shares Alford's enthusiasm, of course. Susan Arnot, public relations director for Elizabeth Arden, says she's heard of sugaring and can see its novelty appeal in the context of trends toward more natural beauty treatments. "But I can't help thinking if it was so great, it would be more out there," she adds. "We don't do anything of the sort, and don't have any plans to." Is it a trend or just a fad? "I think it will fade," says Arnot.

But Phyllis Aaron, proprietor of Nails, Naturally in Milburn, NJ has no plans to cut down on sugar. "We've been in business for 14 years, the economy is down and we have some competition," she says. But since January, when she started offering body sugaring, her business has soared.

(Reprinted from Ad Week)

Kansas City, MO Hosts 50th

ABF CONVENTION READIES



Now is the time to begin to prepare for the 1993 American Honey Show, says Show Chairman Rick Sutton.

The American Honey Show is a feature of the annual convention of the American Beekeeping Federation, which is set for Jan. 20-23, at the Westin Crown Center Hotel in Kansas City, Missouri.

Preparations are also being made for all other aspects of the convention, the Federation's 50th anniversary celebration. Convention Chairman Troy Fore said topics and speakers are being selected for the program, exhibitors are being contacted for the annual Trade Show, arrangements for the activities connected with the American Honey Queen are being made, and tours to attractions around Kansas City are being booked.

"With good honey production in many areas, we should have a nice representation for the Kan-

sas City show", Mr. Sutton says. "We have entries from all sizes of producers - from hobbyists to commercial."

Entry forms and rules for the Honey Show are available from the Federation office. The entry fee is \$3.00 per entry. Entrants must be members of the Federation.

Trophies will be presented to the first place winners in each of the 13 classes. A best of the show award will be presented for the best individual entry in the show. Ribbons will be awarded for first, second, and third place winners.

After the show, the entries will be auctioned with the proceeds going to the benefit of the American Honey Queen program.

For Honey Show entry forms and show rules or for information on any other part of the convention, contact the American Beekeeping Federation, P.O. Box 1038, Jesup, GA 31545, ph. 912-427-8447.

BEEKEEPING COURSE 'AIRS' FROM OHIO

One of America's oldest agricultural industries is the topic of a television series being produced by Ohio State University this fall.

"Beekeeping: Exploring a Unique Industry" runs on Wed. from 5:30 to 7:30 p.m. Eastern time between Sept. 2 and Dec. 9. The series is available to anyone with a satellite receiving dish on Spacenet 1, Channel 5.

This series is hosted by James E. Tew, Ohio State's nationally known bee expert. It's being car-

ried on the Agricultural Satellite Corporation (AG*SAT) Network. University credit is available from Ohio State and other land-grant universities that are part of AG*SAT.

The course is designed for both those people involved in the beekeeping business and those who are interested in the business. Discussion topics include beekeeping equipment, swarms, the business of beekeeping, honey processing and uses, and an over-

view of stinging insects commonly confused with honey bees.

Each week Tew will travel across the country to explore how industries and individuals are using honey and beekeeping within their businesses. He'll also call on guest speakers from industry and academia to add variety and expertise to the programs.

For more information on broadcasts, contact Mitch Jacobs at OH State, (614) 292-2011, or Jim Tew at (216) 264-3911.

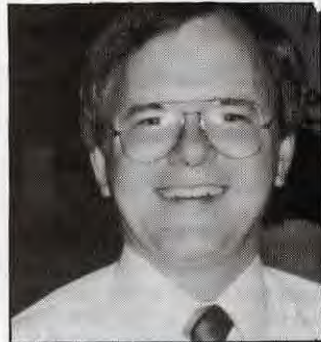

Jim Tew

Beekeepers Moving Bees, Beware

SLOW VEHICLES ARE TROUBLE

On the night of May 14, 1988, a Stark County, OH man was killed as he drove his tractor. It was struck from behind by a car.

On July 8, 1989, two motorcyclists were killed in separate accidents when they ran into the back of farm wagons. One of the victims was 16 years old.

On March 28, 1990, a driver was killed and a passenger injured when their car crashed into the back of a tractor. The tractor was traveling 20 mph. The car's cruise control was set at 58.

"Slow-moving vehicles represent a very small percentage of the total miles traveled on public roads, but they account for a disproportionately high number of accidents," says Thomas L. Bean, safety specialist at Ohio State University. And beekeepers moving bees sometimes fall into that category. Especially when pulling trailers, or have overloaded trucks.

But Bean is launching a two-year study to help prevent such accidents in the future. He and other researchers in the OSU Department of Agricultural Engineering have been granted \$235,000 to evaluate driver response to slow-moving vehicle identification and lighting systems.

They will study responses in actual outdoor settings and in a driving simulator machine. Lighting and marking systems currently in use will be compared with alternatives to find the most effective system.

Bean says the study has three key aspects:

- To find the most effective way for drivers to identify slow-moving vehicles.

- To test the visibility of extra-wide or long equipment.

- To find the most effective way for slow-moving vehicles to signal turns, which is often a factor in accidents.

The study will test driver response time in daytime, dusk and nighttime driving conditions and a range of weather and seasonal conditions. Drivers will represent all age ranges, and all levels of driving experience and familiarity with slow-moving equipment on roads.

Ironically, it was 30 years ago that Kenneth Harkness, another Ohio Extension agent invented the now nationally used familiar triangle sign. He did it with a little ingenuity, a lot of research and a \$20,000 grant from a safety association. Its use reduced deaths by 50% in less than a decade.

Canada's Count Down

SURVEY COUNTS BEES & KEEPERS

The latest census of agriculture shows there are 4,243 bee farms in Canada with a collective 450,861 hives.

Ontario had, by far, the largest number of beekeepers, but Alberta recorded the highest number of colonies.

Statistics Canada defines a farm as an agricultural holding that produces an agricultural product intended for sale.

The latest survey showed that the total number of Canadian farms has fallen in the last five years by 4.5% to 280,043. The number of farms increased in only two provinces - British Colum-

bia and Newfoundland.

The farm review, conducted every five years by Statistics Canada, showed the following provincial breakdown of beekeeping activities:

Province	Farms	Colonies
Newfound.	3	87
PEI	39	723
Nova Scotia	125	5,514
New Bruns.	113	3,759
Quebec	564	36,043
Ontario	1,487	73,219
Manitoba	345	71,668
Sask.	344	81,351
Alberta	529	147,706
B.C.	694	30,791

HONEY BOARD HIGHLIGHTS

FREE BROCHURE Cooking and storage tips, easy use suggestions, simple recipes and fun honey facts are included in a new brochure.

The cover of the brochure features the lovable squeeze bear proclaiming "Honey, chances are you'll love me once you get to know me."

Consumers will learn about honey's diverse forms, flavors and uses in this information-packed brochure.

To receive a complimentary copy of the brochure. Send a self-addressed, stamped envelope to: National Honey Board, 421 21st Ave., #204, Longmont, CO 80501

Additional copies are available for 50¢ each.

FREE RECIPES The cute, friendly honey squeeze bear wants an invitation to your next party. Quick and easy party recipes are the theme of the "Invite me to your next party" recipe leaflet from the National Honey Board.

The leaflet is ready for your next local promotion or as an insert with your honey package. Beekeeping associations and supporters of the National Honey Board can order up to 500 recipe brochures free of charge. Additional brochures are available at 5¢ each.

Pollination Requirements Up, Too

ALMOND PRODUCTION UP IN '92

The 1992 almond production in California is forecast at 550 million pounds (shelled basis), up 12% from last year. This forecast is based on an estimated bearing acreage of 380,000 acres.

The 1992 almond crop appears to be in good condition with progress approximately two weeks ahead of last year. Generally, trees in the southern San

Joaquin Valley show a lighter nut set and trees in the northern Sacramento Valley have a heavier set. Overall nut set is higher than last year. The low set in the San Joaquin Valley may be the result of last year's reduced water supply. Insects are also a potential problem, they have appeared earlier in the growing season and in larger numbers.

MORE TREES MEAN MORE BEES

Small trees that yield as much fruit as large trees have been bred by scientists with USDA's Agriculture Research Service. Nectarine and peach trees require less pruning, are easier to harvest, and

can be planted in higher densities, reducing land and operating costs. However, pollination costs will increase because colonies/acre will need to increase to compensate for additional bloom.

SEND YOUR NEXT MEETING NOTICE TO THE GLOBE. ADVERTISE YOURSELF!!

Paperless News

NEW JOURNAL ON DISK AVAILABLE

A new paperless environmental journal has just been published on computer disk in Macintosh and IBM-compatible formats. The GreenDisk is a unique concept in environmental information exchange, providing environmental professionals, journalists librarians, activists, environmental studies teachers, students, and others with a comprehensive resource documenting the work that is going on within the environmental community. Hundreds of different sources are scanned, ranging from marine mammal protection to toxic waste disposal. The GreenDisk is a forum for the publication of research reports, press releases, action alerts, and news summaries from the world's

environmental groups and governmental agencies.

Subscriptions to The GreenDisk are \$35 per year (6 issues). Submissions of research reports, press releases, action alerts, jobs or volunteer opportunity listings, upcoming conferences or events are encouraged. The best way to submit the information is through the electronic networks, or by mailing a disk. The GreenDisk can be reached on EcoNet (greendisk) and CompuServe (70760, 2721) and BITNET (greendisk@igc.org). To obtain an order form and subscription information, write: The GreenDisk, Box 32224, Washington, DC 20007 USA.

PA CALENDARS READY

The 1993 PSBA Beekeepers' Calendar is available for sale by mail to any interested individual at a cost of \$5.00 each, postage paid. (They will also be for sale at the 1992 PSBA Annual Winter Meeting on November 14, 1992, in Lewisburg, PA.) Calendars will be shipped after September, 1992.

Please indicate the quantity desired and enclose a check for the appropriate amount payable to "PSBA". Please mail all calendar orders to the following address: 1993 PSBA Beekeepers' Calendar, c/o Brenda Aucker, 316 Jackson Street, Bloomsburg, PA 17815.



ITALIAN QUEEN & PACKAGES



Frank & Sheri Pendell
P.O. Box 148
Stonyford, CA 95979
(916) 963-3062



Call for Quotes & Quantity Discounts

PENDELL APIARIES

USDA To Oversee Release

HONEY BEE STOCK TO BREEDERS

A panel consisting of scientists and industry representatives has been created to deal with the release of honey bee stock from the Agricultural Research Service to breeders.

Rather than ARS itself undertaking the extensive job of increasing and maintaining stocks, the Stock Release Panel will select two to four breeder-propagators to do so for each newly released honey bee stock.

"The panel will ensure that distribution to the industry will be equitable," said ARS insect geneticist Tom Rinderer, who chaired the committee that created the panel.

ARS has been importing potentially useful stock through quarantine as part of its breeding program to solve critical problems in the honey bee industry.

Contracts between the panel and breeder-propagators will govern stock maintenance, distribution, and sales requirements as well as prices and service fees.

Regardless of who receives the rights to propagate stock by being selected as a breeder-propa-

gator, the ownership of all stocks will be retained by ARS.

Breeder-propagators will be required to provide stock to all queen producers who have signed a cooperators' contract and ordered bees by the first of August following the announcement of a release. No order received by that deadline may be refused without the specific consent of the panel.

On rare occasions, the Stock Release Panel may recommend that ARS itself act as the breeder-propagator. In that case, stock will be provided to no more than 10 queen producers a year.

Successful applicants will each pay \$1,000 to be contracted as breeder-propagators. The funds will be used by the Stock Release panel for additional importation and research of honey bees.

The panel will consist of a chairman from ARS and one representative from each of four industry associations: American Bee Breeders Association, American Beekeeping Federation, American Honey Producers Association, California Bee Breeders Association.

NEW PRODUCT DEBUTS



The E.P. Geister Manufacturing Co. has been granted an exclusive licensing agreement by the Agriculture Department to manufacture and sell a new U.S. patented sliceable honey product.

The production process involves forming honey into a solid block, pre-slicing it and packaging it in a fashion similar to sliced cheeses or meat products. This

sliceable honey product also has various uses in the confectionery industries for making chocolate coated honey bars, etc.

Certain Midwest and East Coast areas would be available to interested parties under a sublicense agreement. For details, contact: E.P. Geister Mfg. Co., P.O. Box 309, Little Switzerland, NC 28749 (704) 765-0408.

Pollination Income Potential

CHERRY PRODUCTION UP IN '92

Tart Cherries

U.S. tart cherry production is forecast at 261 million pounds, up 37% from last year and 25% more than 1990.

The largest producing state, Michigan, expects a crop of 185 million pounds, up 68% from last year and 16% more than 1990.

Production in New York is forecast at 24.0 million pounds, down 6% from the 1991 crop. The bloom was good this year.

The Pennsylvania crop is expected to be less than half the size of last year's crop. Last summer's drought and spring frost damage appear to be the main contributors to the reduction. The average date of full bloom was May 1, a week later than last year. Harvest is expected to be nine days later than last year, about July 4.

Wisconsin's forecast at 7.30 million pounds, is 6% less than the 1991 crop. A spring freeze, hail, and high winds combined to reduce the crop.

Sweet Cherries

Increased production in the Western states, except CA, offset reduced production in the Great Lakes states. The result is a forecast of 192,900 tons, up 27% from last year and 23% more than 1990. Production in the Great Lakes states fell 18%, while production in the Western states rose 36%.

The Michigan crop, at 18,000 tons, is 18% less than last year's crop.

New York expects a crop 12% less than last year, at 1,100 tons. Bloom was the best in several years and showed good crop potential at the start.

Production of 800 tons is expected in Pennsylvania. This level is 27% less than 1991 production. Adverse weather conditions last summer and this spring weakened the trees and lowered bloom. The average date of full bloom was April 29, nine days behind last year.

WETLANDS PROBLEMS

A storm of controversy has erupted regarding changes that the U.S. Department of Agriculture is considering making to wetlands delineation criteria under the swampbuster provisions of the 1985 and 1990 Farm Bills.

An internal USDA working paper, discussing various options for delineating wetlands, was leaked to the media in late May. As a result, some members of the environmental community have charged that USDA is attempting to weaken swampbuster and further retreat from the Bush administration's "no-net-loss" wetlands policy.

"In looking at delineation alternatives, one problem that USDA's Soil Conservation Service is attempting to address is the tremendous workload facing the agency in carrying out wetland determinations," explained NACD President Gerald Digerness.

There are still about 30 million acres that must be delineated under swampbuster. Some of these acres may contain several wet areas, each of which must be delineated individually. "Such a dif-

ficult and time-consuming process would further burden a field staff that's already stretched to the limit," Digerness noted.

One alternative being considered by SCS is the use of cropping history to make delineations on approximately 10 million acres that fall into a category called farmed wetlands - small tracts of land that are farmed more often than not, but that might be considered wetlands if cropping were to cease.

"In some areas of the country, cropping history could provide a good indicator of whether an area is a functional wetland. In other areas developing a minimum size threshold could be a workable alternative. And both cropping history and size thresholds are readily verifiable," said Digerness.

"But whatever the final procedure, it should be simple enough that clear guidance can be provided to field staff and flexible enough so that variations can be applied in different areas of the country as long as they are consistent with national guidelines," he concluded.

Don't Guess! Find Out HOW-TO-DO Nearly Every Beekeeping Task! — Do It Right The First Time



Cat. No. X76

\$20.95 postpaid

•BEEKEEPER'S HANDBOOK

Great for beginners, intermediate and even skilled beekeepers. Covers everything from package installation to harvesting honey. A great learning tool.

•COLONY RECORD BOOK

A sturdy, 3-ring notebook complete with tabs and 2-sided, 50 sheet pad for keeping track of EVERY colony activity. Don't guess. Take notes and take them right.

Cat. No. X22

\$10.99 postpaid



Also available:
Cat. No. X38 Equipment Supply Record Pad

\$4.99 postpaid

Cat. No. X52 Sales & Purchases Record Pad

\$4.99 postpaid



•STARTING RIGHT WITH BEES

Completely rewritten and updated. New chapters include Social Beekeeping, Associations and Keeping Bees in Town. A HUGE glossary and many photos added. The best selling beginner's book on the market.

Cat. No. X84

\$7.99 postpaid



1-800-BUY-ROOT

CALENDAR ... Cont. From Pg. 583

Every new member who joins between August 1, 1992 and November 14, 1992, will receive a FREE 1993 Beekeepers' Calendar, filled with beekeeping photos, a list of all Pennsylvania beekeeping associations, a resource list for beekeeping information, meeting dates, honey recipes, colony management tips, advertising, a fun beekeeping scavenger hunt contest, and much more!

PSBA membership applications and sponsorship forms are available through all county beekeeping associations, or request from the address listed below. Membership dues are \$8.00 per person per year. Please make all checks payable to "PSBA" Please send all membership inquiries and dues payments to the following address: PSBA Membership Drive, c/o Yvonne Crimbring, Secretary/Treasurer, RD #1, Box 315, Canton, PA 17724.

★ TENNESSEE ★

The Tennessee State Beekeeper's Association will hold its 87th annual convention October 15 - 17, 1992 at Wilson World Hotel, 2715 Cherry Rd., Memphis, TN.

For reservations call 1-800-945-7667. For more information contact Bill Lane at 5801 Vassar Dr., Memphis, TN 38119, (901) 683-7494.

★ TEXAS ★

The 24th Annual Convention of the American Honey Producers Association will be held at the Sheraton Crown Hotel and Conference Center in Houston, TX from January 5 to 10, 1993. The meeting will include educational sessions, an informal reception, an annual banquet, and meetings of the executive committee, directors, and general membership. All beekeepers may attend and participate in all aspects of the convention, although only members may vote in the business meeting. Tours will be announced later.

A special Saturday Seminar in Beekeeping will be held on January 9, 1993. This seminar will feature key beekeeping scientists and industry leaders in an intense, one day beekeeping review session. Beekeepers who are unable to attend the entire convention are invited to attend the Saturday Seminar in Beekeeping.

The Sheraton Crown Hotel is located at 15700 JFK Boulevard, Houston, TX 77032. The location is just a few miles from Intercontinental Airport. The phone numbers for the Hotel are: 800-444-2217, 713-442-5100 and FAX: 713-987-9130.

To obtain general mailing information about the conference, write AHPA, P.O. Box 584, Cheshire, CT 06410.

★ WISCONSIN ★

The Wisconsin Honey Producers will hold their annual fall meeting on Friday and Saturday, November 6 & 7, 1992, at the Holiday

Inn Airport Green Bay, in Green Bay, WI.

The meeting starts at 8:30 a.m. on Fri and runs to 5:00 p.m. There is a raffle and awards presentation that evening.

On Saturday, the meeting starts at 8:30 a.m. and runs to lunch. There is a lunch-time speaker both days. Sat. afternoon there will be a tour of the Green Bay Packers Museum.

Speakers include Sue Cobey, Kim Flottum, Bob Smith, Annette Phibbs, Marla Spivak, and Jennifer Thomas. For more information contact Chris Werner (414) 675-2050.

INNER ... Cont. From Pg. 536

It was only a 10 minute spot but it was an incredible experience. Bright lights, cameras, questions a real rush.

If you're interested in this series I urge you to tune it in, or find somebody who can and catch it there. And call in at the end. If you've missed the first few shows don't fret, they were taped, and you can get them (only I'm not just sure how, yet).

For more information write: Dr. James E. Tew, The Ohio State University, 1328 Dover Road, Wooster, OH 44691 or call: (216) 264-3911; FAX (216) 262-2720; Internet: TEW.1@OSU.Edu

It'll be a great way to spend Wednesday evenings (or afternoons, I guess for those on the west coast).

Kim Flottum



Since St. Jude Children's Research Hospital opened in 1962, it has forged new treatments for childhood cancer and has helped save the lives of thousands of children around the world. But the battle has just begun. You can join the fight. To find out how, call 1-800-877-5833.

ST. JUDE CHILDREN'S RESEARCH HOSPITAL

Danny Thomas, Founder



BEEKEEPERS MEETING

SUPERFRAMES™ UNFOUNDATION SYSTEM
 A Smart Alternative • SASE For Information
Simon
 504 Maple St. #2 • Santa Cruz, CA 95060
 (408) 423-1864

TO ORDER: CALL 1-800-289-7668



165PS

164PS





163PS

ROOT

Show Pride in Your Product
 Show everybody you sell *only* made in America Honey!

Use these attractive Pressure Sensitive labels on every jar you sell for only 2-1/2¢ each!

ONLY \$6.49
 For a roll of 250 Post Paid

THREE BANDED ITALIAN QUEENS

Swarms shipped from Georgia

Clipping or marking 40¢ each.

LIVE DELIVERY GUARANTEED

Price includes Apistan Queen tab.

Queens –

1–24\$4.50

25 & up\$4.00

Write for Free 1992 Catalog

The Walter Kelley Co.
CLARKSON, KY U.S.A. 42726-8064

Phone: (502) 242-2012
FAX (502) 242-4801

TERRAMYCIN

SOLUBLE POWDER & OXYTETRACYCLINE-50
HONEY BEE PREMIX

(Ingredients: Oxytetracycline Hydrochloride, Sucrose)
50 Grams/lb.

Cat. 360 – 6.4 OZ. SOLUBLE POWDER TM-25
SHIP WT. 1 LB. — \$4.00

*Cat. 361 – 5 LBS. OXY-50 BEE MIX
SHIP WT. 6 LBS. — \$20.50

*Cat. 363 – 50 LBS. OXY-50 BEE MIX
SHIP WT. 53 LBS. — \$185.00

*Same Concentration & Diluent as Terramycin 50-D.

ADD PARCEL POST OR UPS ON ORDERS UP TO 70 LBS.

WALTER T. KELLEY CO.
CLARKSON, KY. 42726
502-242-2012
FAX 502-242-4801

Display Ad Index

Bees & Queens

Glenn Apiaries	576
Hardeman Apiaries	555
Holder Homan	576
Koehnen, C. F. & Sons	541
Kona Queen Co.	543
Pendell Apiaries	581
Plantation Bee Co.	557
Rossmann Apiaries	565
Shuman's Apiaries	557
Strachan Apiaries	557
Weaver Apiaries, Inc.	574
Weaver, How. & Sons	555
Wenner Honey Farms	556
Wilbanks Apiaries	578
York Bee Co.	533

Education

African Bee Video	543
American Honey Producers	576
Global Nature Tours	576
Hobby & Art Work	543
WICWAS Press	584

Equipment

Better Way Wax Melter	578
CC Pollen	538
Clement's Apiaries	543
Cook & Beals	555
Cowen Mfg. Co.	567
Dakota Gunness	557
Glick's Custom Tarps	578
Golden Containers	555
Hackler's Honey Punch	557
Hive Tops	576
Miller Wood	576
NME Microscopes	545
Pierco Inc.	543
Pourette	557
Simon Super Frames	586
Southwestern OH Hive Parts	538
Stoller Honey Farms	576

Related Items

Beehive Botanicals	584
Bob Berthold Candle Molds	584
Candlewic	574

Cricket Science	541
Custom Labels	541
Rich Fleming Beeswax	555
R. M. Farms Labels	556
St. Simons Trading Co.	576

Suppliers

B & B Honey Farm	565
Better Bee	567
Brushy Mtn. Supplies	559
Chrysler, W.A. & Son	576
Dadants	Inside Front Cover
Draper's Super Bees	556
Jones, F. W. & Son	543
Kelley, Walter	587
Mann Lake Supply	554
Maxant Industries	538,557
Mid-con	565,569
Perma-Comb Systems	555
Ross Rounds	543
Root Publications	533,540,582
Scentry	538
Zocon	Back Cover

There are people in this county who think I know a lot about gardening. That's because I wrote a newspaper column headed by my picture, and titled "Gwen's Garden - in an Ozark Clearing" Sure I garden, but the column was mostly observation rather than advice. I wrote about the influence of stars on soil and growing things, and the mysterious magical influence of elder trees and stinging nettle on plants around them, and things like that - the invisible side of gardening. So people called and asked if I knew why a bluebird kept pecking at a window; and was it true a dowser could locate ley-lines in the earth.

Well, that was fun, and I found I had friends I'd never met. I also learned a lot because I had to look up answers.

But I never found out why we can't catch a mole. They tunneled our raised beds and killed tender young plants whose roots were left hanging in soilless air spaces. We tried *all* the expensive traps, and poured water and calcium carbide down tunnels to gas them, but they'd just move over and dig another tunnel. We wanted to catch a couple, skin them, burn the skins and sprinkle the ash on the beds. However this must be done when Venus is in the sign of Scorpio. *That* would chase them! But we never caught a mole.

We never found out why armadillos are moving in from the south either. We managed to fence them out of the garden, but they dig holes all through the grassy yard, and even dug up some turtle eggs we watched a box turtle laying in a flower bed. That was sad. We never had armadillos before this year, except a very occasional one someone would bring in to the newspaper office to be photographed. Do armadillos eat bees? Their anteater snouts likely could pick up bees at a hive entrance, but they are mostly nocturnal. But then so are skunks.

There's one more mystery we're wondering about: where did the bees come from this summer? We used to have two hives for our own honey and pleasure, but we lost one to the disappearing disease a few years ago, and were going to divide the remaining one this spring. A hospital session not only interfered with the dividing; it left the bees untended in early spring and they too dwindled to a pitiful handful, and we had to postpone getting more until next year. In the meantime varroa mites arrived in the area and killed whole apiaries. So we had *no* bees all spring.

We live in a remote Ozark forest where there are only four families on a six-mile gravel road, each family at least a mile off the road, usually in a "holler" None of our neighbors have beehives. In fact the nearest hives are at least 10 miles away.

There were no bees on any of our plants or flowers this spring (our garden bloom time begins in March) until the elderberry bush beside the shop bloomed in May. One morning we heard the blossoms buzzing and sure enough, we counted six honey bees! We were ecstatic. Could there be a feral colony in the woods as of yet untouched, or better, resistant to varroa mites? Or would they soon disappear again?

When early carrots were pulled and the bed planted to buckwheat for an interim ground cover, the bees showed up again, this time more of them. Should we examine some for mites? If we found them we couldn't treat them anyway, because they had to be a "wild" colony in a tree somewhere. And we do not go romping through the woods here in summer. Ticks and chiggers would eat us alive. I am not a one-track-minded scientist oblivious to physical pain and hardship in the name of research. I am just a gardener who is willing to wait and see. Meanwhile I read Roger Morse's article about the leg-biting bees who defeat varroa

mites, and like to believe somewhere out there in the forest is a bee tree where varroa-resistant bees live and find their way to my garden.

Is it any wonder? It only goes to prove once more the hardiness, independence, and wisdom of all native Ozarkians, including moles, armadillos and bees.

And, yes, I know a dowser who *can* locate ley-lines, those invisible lines of force that criss-cross Earth's surface. Planning an orchard so that trees are planted at the junctions of ley-lines should contribute to maximum production; that is if honey bees keep coming back.

Why *do* birds peck at windows? I've heard they are defending their territories against that other bird, but I wonder.

Is It Any Wonder?

GWEN EISENMANN

BOTTOM BOARD